



SIE-S626-11D
DESCRIPTIVE
INFORMATION

AC ADJUSTABLE SPEED DRIVES FOR MACHINE TOOL SPINDLES

Varispeed®-626MTII

B SERIES DRIVES

SERVICE MANUAL

5.5 TO 26 kW (30-MINUTE OPERATION RATING)

3.7 TO 22 kW (CONTINUOUS OPERATION RATING)

This service manual covers types CIMR-MTII-5 5 KB through -26 KB of our machine tool spindle AC drive units *Varispeed-626MTII* (VS-626MI).

The VS-626MTII is comprised of a squirrel-cage induction motor controlled by a vector-controlled inverter making its performance comparable to a DC drive system. The VS-626MTII is designed for highly reliable operation in industrial atmosphere, and requires only minimum maintenance service, which is described in this manual.

上正科技有限公司

購買、維修 此手冊零組件

電話： 037-466333

Email: service@repairtw.com

line id: @zzzz

www.repairtw.com

AC Spindle Motor
Flange-mounted
Type EEVA-5IKM

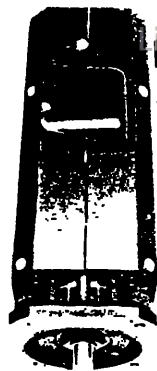

VS-626MTII
Type CIMR-MTII-7 5KB

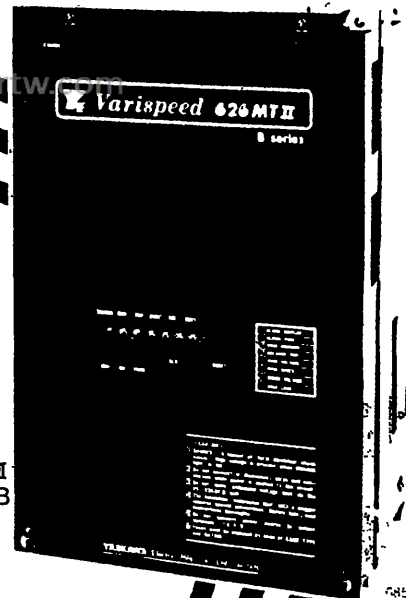

AC Spindle Motor
Foot-mounted
Type EEA-1KM



CONTENTS

	Page
1. STANDARD SPECIFICATIONS	5
2. CONFIGURATION	6
2.1 SYSTEM CONFIGURATION	6
2.2 COMPONENTS OF VS-626MTII AND AC SPINDLE MOTORS	6
3. OPERATIONAL DESCRIPTION	9
4. VS-626MTII BLOCK DIAGRAM	11
5. INSTALLATION	12
5.1 MOTOR	12
5.2 VS-626MTII CONTROLLER	12
6. WIRING	14
6.1 INTERCONNECTIONS	14
6.2 LEAD SIZE	15
6.3 WIRING INSTRUCTIONS	16
7. PREPARATION FOR OPERATION	19
7.1 CHECKS BEFORE TEST RUN	19
7.2 CHECKING POWER UNIT AND PRINTED CIRCUIT BOARDS	19
7.3 SHUNT CONNECTOR SETTING	20
7.4 ADJUSTMENT OF SETTING SWITCH	21
7.5 CHECKING POTENTIOMETER SETTING	23
7.6 CHECKING POWER SUPPLY VOLTAGE	23
8. ADJUSTMENT DURING TEST RUN	24
8.1 CHECKING AFTER POWER ON	24
8.2 OPERATION	26
8.3 ADJUSTMENT	27
9. MAINTENANCE	32
9.1 DAILY INSPECTION ITEMS	32
9.2 PERIODIC INSPECTION	33
9.3 CHECKING POWER SEMICONDUCTOR ELEMENTS	34
9.4 REPLACEMENT OF PRINTED CIRCUIT BOARDS	36
9.5 TROUBLESHOOTING	41
10. SPARE PARTS	55

INDEX

Subject	Chapter	Section No.	Page
A ADJUSTMENT	8	8.3	27
ADJUSTMENT DURING TEST RUN	8		24
Adjustment of Accel/Decel Time (TIME)	8	8.3.8	31
Adjustment of Load Meter (LMADJ)	8	8.3.3	29
Adjustment of Loop Gain of Speed Control System (N GAIN)	8	8.3.7	31
Adjustment of Motor Speed (NADJ, NREV)	8	8.3.1	28
ADJUSTMENT OF SETTING SWITCH	7	7.4	21
Adjustment of Speed Coincidence Detection Level (N DET)	8	8.3.5	30
Adjustment of Speedometer (SMADJ)	8	8.3.2	29
Adjustment of Torque Detection Level (T DET)	8	8.3.6	31
Adjustment of Torque Limit (TLIM)	8	8.3.4	30
C Check of AC Spindle Motor	8	8.1.1	24
CHECKING POTENTIOMETER SETTING	7	7.5	23
CHECKING POWER SUPPLY VOLTAGE	7	7.6	23
Check of VS-626MTII Controller	8	8.1.2	25
CHECKING POWER UNIT AND PRINTED CIRCUIT BOARDS	7	7.2	19
CHECKING POWER SEMICONDUCTOR ELEMENTS	9	9.3	34
CHECKING AFTER POWER ON	8	8.1	24
CHECKS BEFORE TEST RUN	7	7.1	19
COMPONENTS OF VS-626MTII AND AC SPINDLE MOTORS	2	2.2	6
CONFIGURATION	2		6
D DAILY INSPECTION ITEMS	9	9.1	32
Diode Module	9	9.3.2	35
I INSTALLATION	5		12
INTERCONNECTIONS	6	6.1	14
L LEAD SIZE	6	6.2	15
Location	5	5.1.2	12
Location	5	5.2.1	12
M MAINTENANCE	9		32
MOTOR	5	5.1	12
Mounting	5	5.1.3	12
O Offset Adjustment of Speed Control System	8	8.3.9	32
OPERATION	8	8.2	26
OPERATIONAL DESCRIPTION	3		9
P PERIODIC INSPECTION	9	9.2	33
Positioning	5	5.2.2	13
PREPARATION FOR OPERATION	7		19
Prolonged Storage	9	9.2.1	34

INDEX (Cont'd)

Subject	Chapter	Section No	Page
R Removal of Anticorrosive Paint	5	5.1.1	12
Replacement of Base Drive Board	9	9.4.2	38
Replacement of Control Circuit Board	9	9.4.1	37
Replacement of Cooling Fan	9	9.4.5	40
Replacement of DC Fuses	9	9.4.4	40
Replacement of Power Module	9	9.4.3	39
REPLACEMENT OF PRINTED CIRCUIT BOARDS	9	9.4	36
S SHUNT CONNECTOR SETTING	7	7.3	20
SPARE PARTS	10		55
STANDARD SPECIFICATIONS	1		5
SYSTEM CONFIGURATION	2	2.1	6
T Thyristor Module	9	9.3.3	36
Transistor Module	9	9.3.1	34
TROUBLESHOOTING	9	9.5	41
V VS-626MTII CONTROLLER	5	5.2	12
VS-626MTII BLOCK DIAGRAM	4		11
W WIRING	6		14
WIRING INSTRUCTIONS	6	6.3	16

電話： 037-466333

Email: service@repairtw.com

Line id: @zzzz

www.repairtw.com

1. STANDARD SPECIFICATIONS

Table 1.1 shows the standard specifications of AC spindle motors and VS-626MTII controller.

Table 1.1 Standard Specifications

Mounting		Flange-mounted Type for Machining Center							Foot-mounted Type for Lathe						
Motor Type		EEVA-5IKM							EEA-1KM						
Frame		17TX	17TX	22TX	22TX	25TX	25TX	25TX	EE-112 MTB	EE-132 STB	EE-132 MTB	EE-160 MTB	EE-160 MTF	EE-160 LTF	EE-160 TX
Rated Power kW (HP)	30-minute Rating (50% ED*)	5.5 (7.5)	7.5 (10)	11 (15)	15 (20)	18.5 (25)	22 (30)	26 (35)	5.5 (7.5)	7.5 (10)	11 (15)	15 (20)	18.5 (25)	22 (30)	26 (35)
	Continuous Rating	3.7 (5)	5.5 (7.5)	7.5 (10)	11 (15)	15 (20)	18.5 (25)	22 (30)	3.5 (5)	5.5 (7.5)	7.5 (10)	11 (15)	15 (20)	18.5 (25)	22 (30)
Rated Current A	30-minute Rating (50% ED*)	34	43	74	97	95	105	112	40	53	74	90	95	105	112
	Continuous Rating	25	35	55	75	80	92	98	29	42	55	69	80	92	98
Rated Speed rpm	Base Speed	1500 (40 to 1500rpm constant torque)							1500 (40 to 1500rpm constant torque)						
	Maximum Speed	6000 (1500 to 6000rpm constant power)							6000 (1500 to 6000rpm constant power)						
Torque at Base Speed kg·m (Continuous Rated Power) (lb·ft)		2.40 (17.4)	3.57 (25.8)	4.86 (35.2)	7.14 (51.7)	9.73 (70.4)	12.00 (86.8)	14.28 (103.5)	2.40 (17.4)	3.57 (25.8)	4.86 (35.2)	7.14 (51.7)	9.73 (70.4)	12.00 (86.8)	14.28 (103.5)
Rotor GD ² kg·m ² (lb·ft ²)		0.074 (1.75)	0.098 (2.32)	0.20 (4.74)	0.25 (5.93)	0.39 (9.24)	0.46 (10.9)	0.54 (12.8)	0.066 (1.56)	0.13 (3.08)	0.16 (3.74)	0.27 (6.40)	0.39 (9.24)	0.46 (10.9)	0.54 (12.8)
Overload Capacity		120%, 60s of 30-minute rating							120%, 60s of 30-minute rating						
Cooling Method		Totally-enclosed externally fan-cooled type							Totally-enclosed externally fan-cooled type						
Power Supply for Cooling Fan Motor		Single-phase 200 VAC, 50 or 60 Hz, 220 VAC, 50 or 60 Hz, 230 VAC, 60 Hz		Three-phase 200 VAC, 50 or 60 Hz; 220 VAC, 50 or 60 Hz, 230 VAC, 60 Hz					Three-phase 200 VAC, 50 or 60 Hz, 220 VAC, 50 or 60 Hz, 230 VAC, 60 Hz						
Insulation		Class F							Class E			Class F			
Operating Temperature of Thermal Protector (Normally Closed Type)		155 ± 7°C (298.4–323.6°F)							120 ± 5°C (239–257°F)			155 ± 7°C (298.4–323.6°F)			
Ambient Temperature, Humidity		-10 to +40°C (14 to 104°F), 95% RH or below (no condensation)							-10 to +40°C (14 to 104°F), 95% RH or below (no condensation)						
Vibration*		V-10 or below							V-10 or below						
Noise (A) Level		78 dB or below			80 dB or below				76 dB or below			80 dB or below			
Finish in Munsell Notation		N1.5							2.5PB5/2						
Speed Detector		Multipole resolver (TDIA-72B)							Multipole resolver (TDIA-72B)						
Type CIMR-MTII		55KB	75KB	11KB	15KB	185KB	22KB	26KB	55KB	75KB	11KB	15KB	185KB	22KB	26KB
Power Supply		Three-phase, 200 VAC, 50 or 60 Hz; 220 VAC, 50 or 60 Hz, 230 VAC, 60 Hz (voltage fluctuation + 10 to - 15 %)													
Max Required Power Supply, kVA		9	12	19	24	30	35	40	9	12	19	24	30	35	40
Circuit		PWM transistor inverter													
Control Method		Vector control (with automatic field-weakening control)													
Braking Method		Regenerative braking													
Speed Adjustable Range		40 to 6000 rpm (1:150)													
Speed Regulation		0.2 % maximum speed or below (load variation 10 to 100 %)													
Overload Capacity		120%, 60s of 30-minute rating													
Speed Command Voltage		±10VDC (+, forward and -, reverse) or +10VDC (forward and reverse signals)													
Ambient Temperature At Operation		0 to + 55°C (32 to 131°F)													
Ambient Temperature At Storage		- 10 to + 60°C (14 to 140°F)													
Humidity		10 to 95 % RH (no condensation)													

*Duty cycle

*V5 (vibration of .5 microns or less in full-amplitude) is available on order

Note

1 The rated power is guaranteed where power supply is 200VAC.

50 or 60Hz, (220VAC 50 or 60Hz, 230VAC, 60Hz) There are some cases where the rated power cannot be obtained even if the power supply fluctuates within the allowable range

2 The spindle motor permits mounting at any angle from horizontal to drive-end-down

2. CONFIGURATION

2.1 SYSTEM CONFIGURATION

With the VS-626MTII, a machine tool spindle AC drive system is configured as shown in Fig. 2.1.

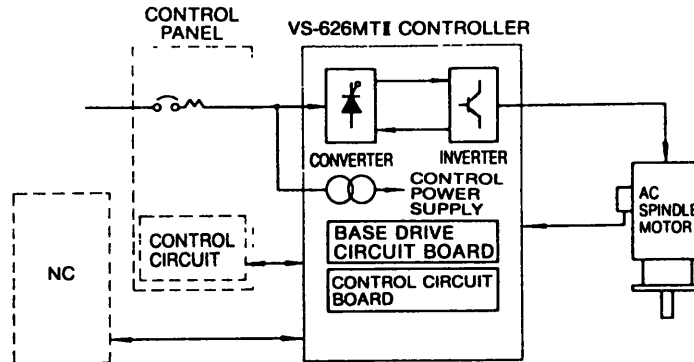

Fig. 2.1 VS-626MTII System Configuration

2.2 COMPONENTS OF VS-626MTII AND AC SPINDLE MOTORS

The construction of VS-626MTII is shown in Fig. 2.2; the frame cover, in Fig. 2.3; and the component layout of VS-626MTII, in Fig. 2.4. The construction of AC spindle motors is shown in Figs. 2.5 and 2.6.

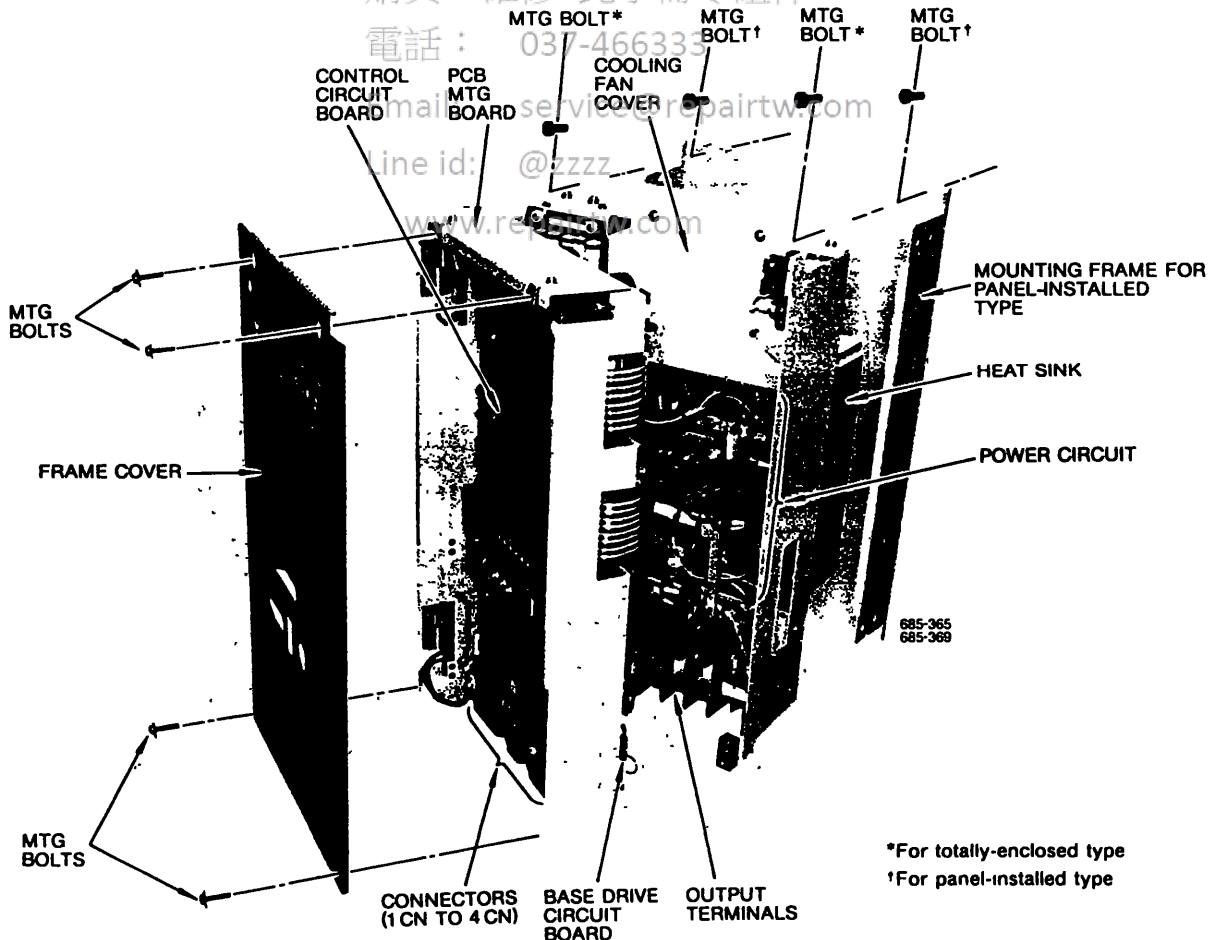

Fig. 2.2 Construction of VS-626MTII Type CIMR-MTII-7.5KB

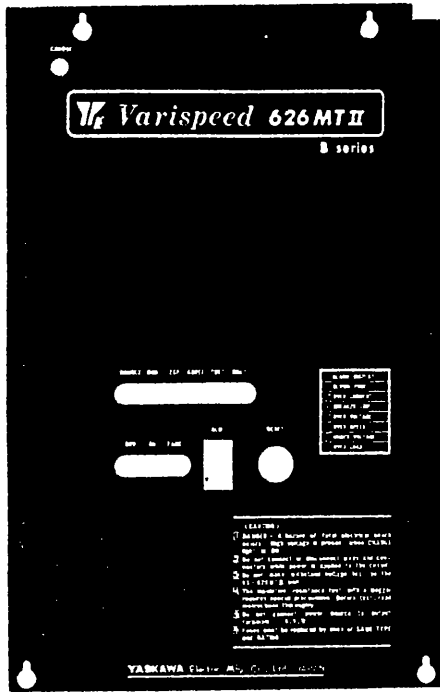
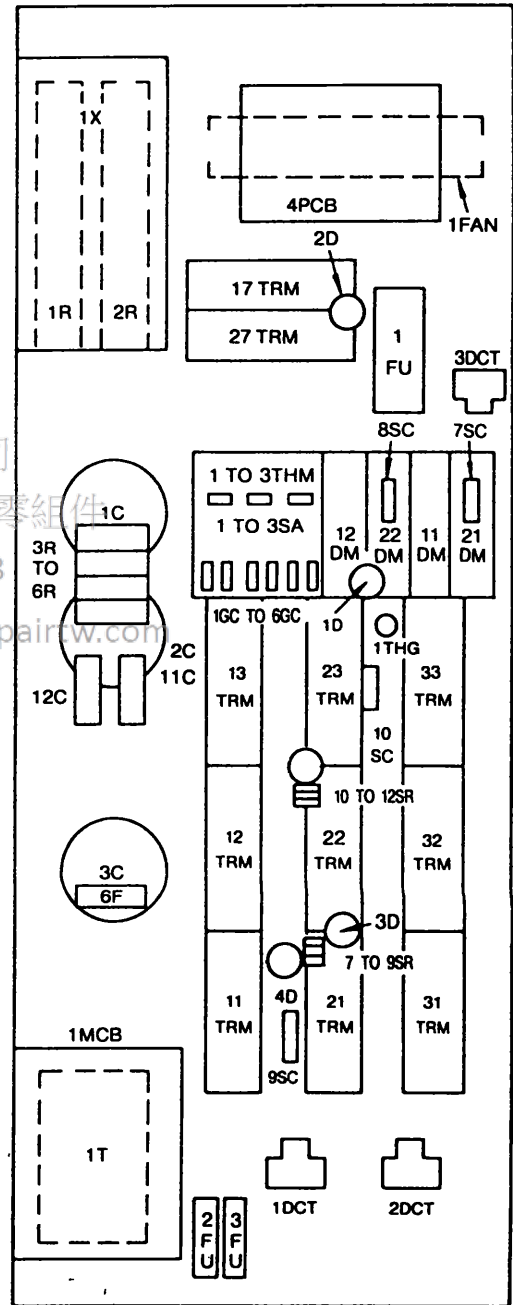

Fig. 2.3 Frame Cover of VS-626MTII



(a) Type CIMR-MTII-7.5KB

(b) Type CIMR-MTII-15KB

Fig. 2.4 Component Layout of VS-626MTII

2.2 COMPONENTS OF VS-626MTII AND AC SPINDLE MOTORS (Cont'd)

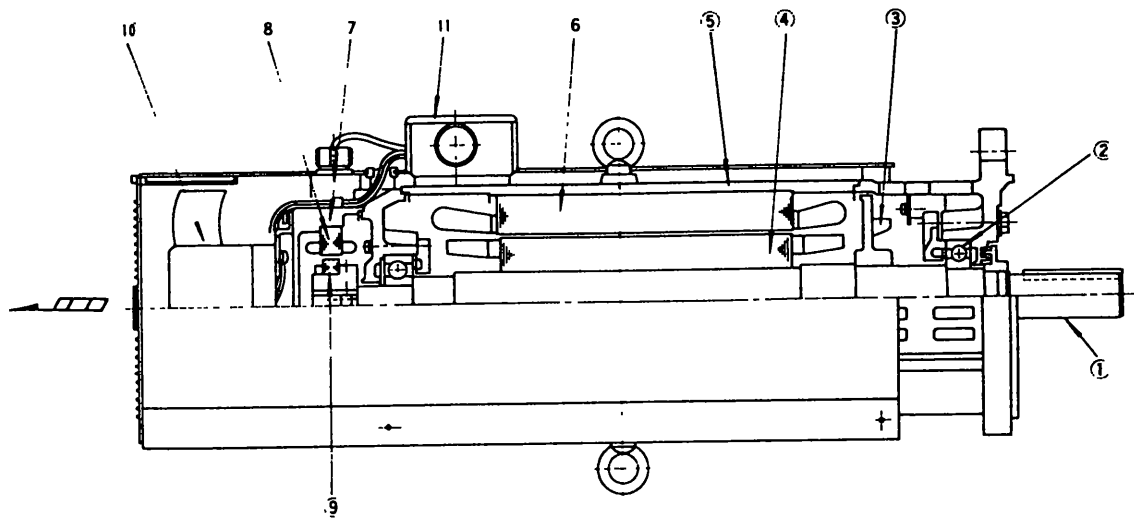

- | | | |
|----------------|-------------------|------------------|
| ① OUTPUT SHAFT | ⑤ FRAME | ⑨ RESOLVER ROTOR |
| ② BEARING | ⑥ STATOR | ⑩ FAN MOTOR |
| ③ FAN | ⑦ RESOLVER FRAME | ⑪ TERMINAL BOX |
| ④ ROTOR | ⑧ RESOLVER STATOR | |

(a) 5.5 to 15 kW (30-minute Operation Rating)

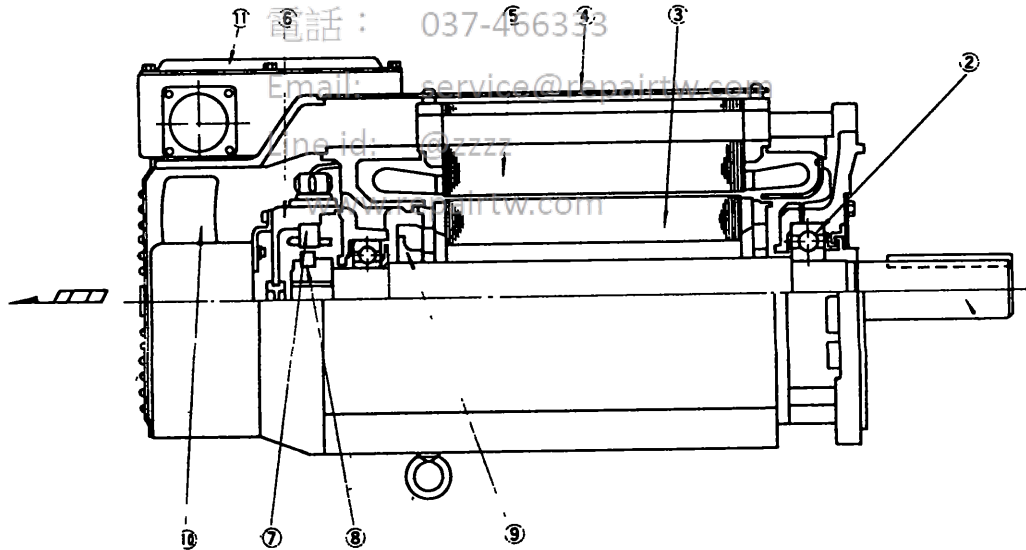

- | | | |
|----------------|-------------------|----------------|
| ① OUTPUT SHAFT | ⑤ STATOR | ⑨ FAN |
| ② BEARING | ⑥ RESOLVER FRAME | ⑩ FAN MOTOR |
| ③ ROTOR | ⑦ RESOLVER STATOR | ⑪ TERMINAL BOX |
| ④ FRAME COVER | ⑧ RESOLVER ROTOR | |

(b) 18.5 to 26 kW (30-minute Operation Rating)

Fig. 2.5 Construction of Flange-mounted Type AC Spindle Motors

3. OPERATIONAL DESCRIPTION

Purpose of the vector control is to independently control an exciting current component (I_m) and a secondary current component (I_2) and to achieve the torque control performance almost equivalent to that of DC machines. T-type equivalent circuit of an induction motor can be normally expressed as shown in Fig. 3.1 and, from this circuit, an equivalent circuit (T-I type) as shown in Fig. 3.2 can be derived containing no leakage reactance of secondary circuit.

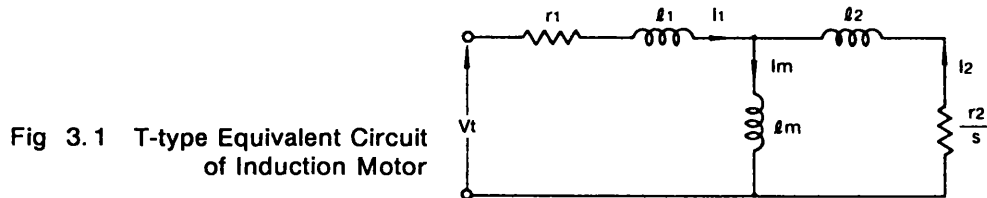

Fig. 3.1 T-type Equivalent Circuit of Induction Motor

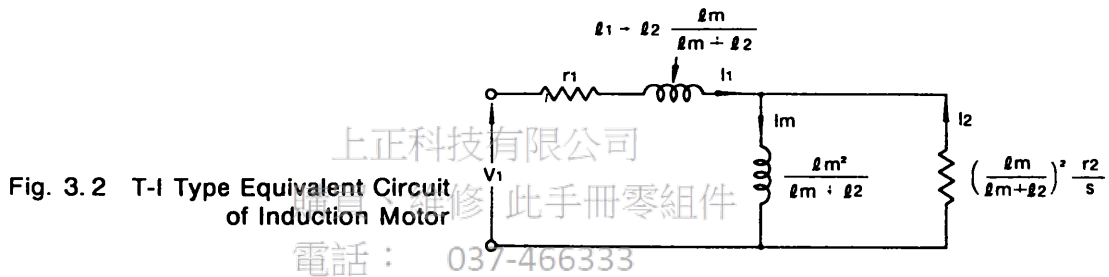

Fig. 3.2 T-I Type Equivalent Circuit of Induction Motor

In Fig. 3.2, the secondary power is expressed as

$$P_2 = \omega \cdot l_m \cdot \frac{l_m}{l_m + l_2} I_m \cdot I_2$$

Therefore, the torque is

$$T = \frac{P}{\omega} \cdot P_2 = P \cdot \frac{l_m^2}{l_m + l_2} I_m \cdot I_2 \text{ (per 1 phase) } \dots\dots(1)$$

Conversely, since the voltage (induced voltage) applied

to $\frac{l_m^2}{l_m + l_2}$ is equal to the voltage of the secondary circuit, the following

$$\text{equation is derived: } \omega l_m \cdot \frac{l_m}{l_m + l_2} I_m = \left(\frac{l_m}{l_m + l_2} \right)^2 \cdot I_2 \cdot \frac{r_2}{s}$$

$$\therefore \omega s = \frac{r_2}{l_m + l_2} \dots\dots\dots(2)$$

If the control is made in such a manner that the following will be met in equation (2):

$$\omega s \propto I_2 \dots\dots\dots(3)$$

Then, I_m becomes constant, that is, the conditions of the constant field system remain valid since l_m , l_2 and r_2 are constants.

If the conditions for equations (2) and (3) remain valid, then the torque of equation (1) is expressed as

$$T = P k_1 r_2 \left(\frac{l_m}{l_m + l_2} \right)^2 I_2$$

Where, $k_1 = \frac{I_2}{\omega s}$

Since P , k_1 , r_2 and $\left(\frac{l_m}{l_m + l_2} \right)^2$ are constant, only I_2 varies when the load varies, so that the exciting current is not affected by fluctuations of the load. Therefore, the exciting current and secondary current can be independently controlled (vector control). A block diagram expressing the concept of vector control is shown in Fig. 3.3, and the corresponding phasor diagram in Fig. 3.4.

3. OPERATIONAL DESCRIPTION (Cont'd)

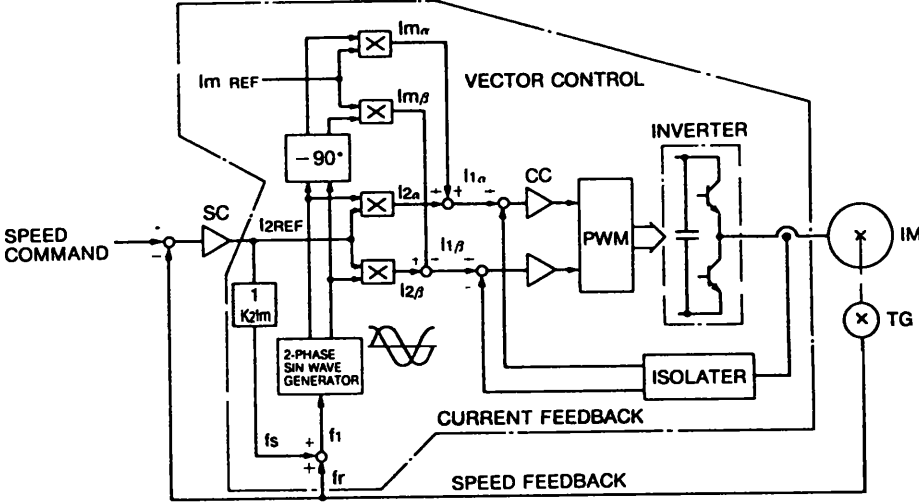

Fig 3.3 Block Diagram of Vecrol Control

購買、維修 此手冊零組件

電話： 037-466333

Email: service@repairtw.com

Line id: q(l2)@zzz

www.repairtw.com

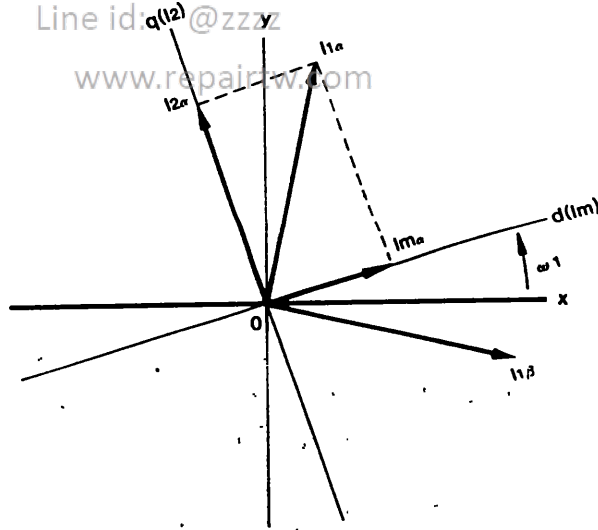

Fig. 3.4 Phasor Diagram

4. VS-626MTII BLOCK DIAGRAM

VS-626MTII block diagram is shown in Fig. 4.1.

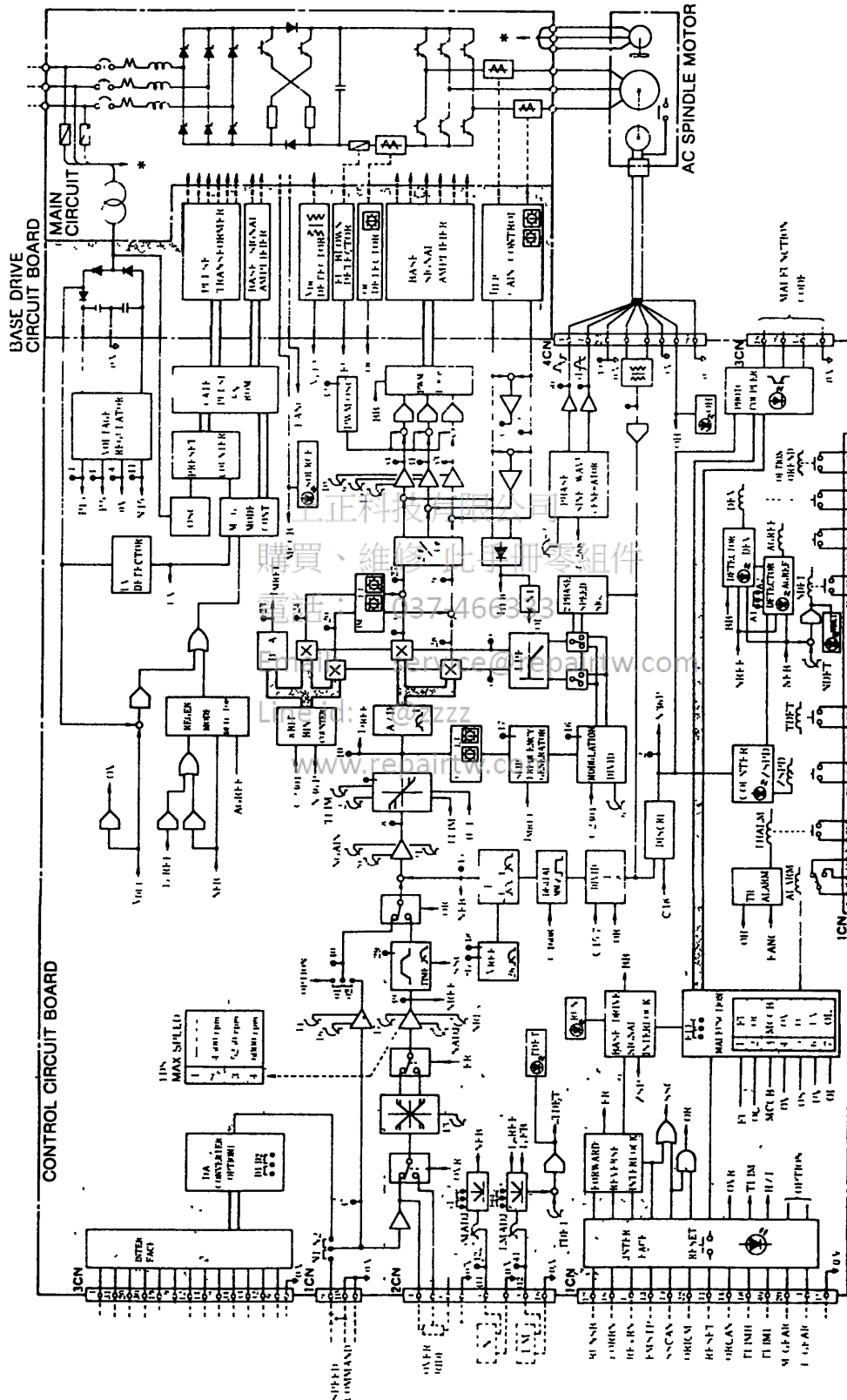

Fig. 4.1 Block Diagram of VS-626MTI

5. INSTALLATION

5.1 MOTOR

5.1.1 Removal of Anticorrosive Paint

Before installing the motor, wash off anticorrosive paint or grease on the shaft extension, keyway and flange surface (only flange type) with thinner. Care should be taken to apply the thinner only to the part containing anticorrosive paint.

5.1.2 Location

The following considerations should govern the location.

- Adequate space for air circulation of motor fan
- Not exposed to excessive cutting liquids or oils—splashes or sprays should be cleaned up as soon as possible.
- Accessible for inspection and cleaning
- Ambient temperature: -10°C to 40°C
- Humidity: 95% RH or below (no condensation)

5.1.3 Mounting

The spindle motor permits mounting at any angle from horizontal to drive-end-down.

5.2 VS-626MTII CONTROLLER

5.2.1 Location

Never move, lift or handle the VS-626MTII cabinet by the front cover or PCB MTG board.

The VS-626MTII controller should be installed in areas where the following conditions are satisfied.

- Protected from rain or dripping water
- Protected from direct sunlight
- Protected from corrosive gases or liquids
- Free from airborne dust or metallic particles
- Ambient temperature: 0 to $+55^{\circ}\text{C}$
- Humidity: 10 to 95% RH (no condensation)
- Free from vibration

CAUTION

The panel-installed type VS-626MTII must be installed in a panel. In this case, inside components of the control panel must be arranged so that the air inhaled by VS-626MTII is 45°C or below. The temperature inside the panel is permitted up to 55°C

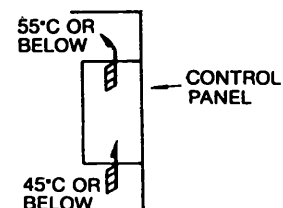

5.2.2 Positioning

For cooling and maintenance purposes, make sure that there is sufficient clearance around the equipment, as shown in Fig. 5.1.

To keep effective cooling conditions, it must be installed vertically to the ground.

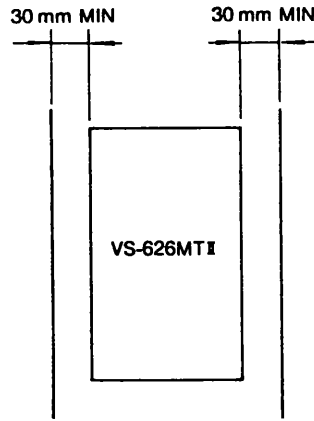

(a) Front View

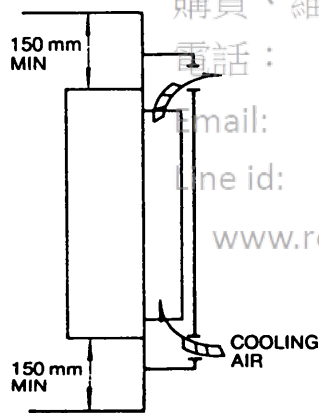

(b) Side View of
Totally-enclosed Type*

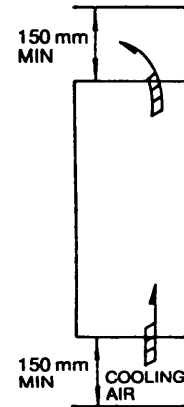

(c) Side View of
Panel-installed Type

* Contact Yaskawa representative when ordering

Fig. 5.1 VS-626MTI Clearance Requirements
for Proper Cooling and Maintenance

6. WIRING

6.1 INTERCONNECTIONS

Fig. 6.1 shows interconnections of AC spindle motor and VS-626MTII, and the input/output symbols. Connections should be made correctly, referring to Fig. 6.1.

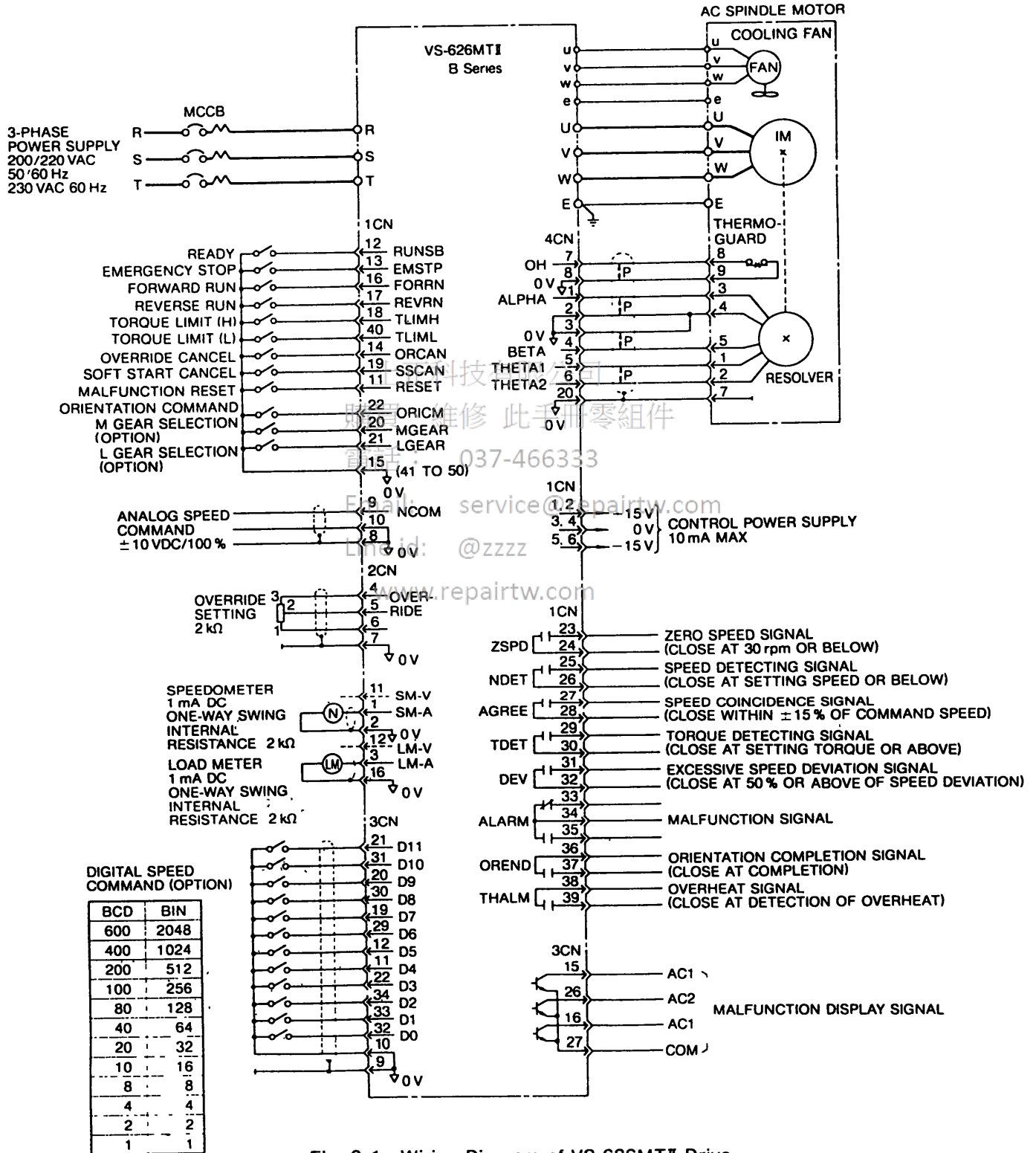

Fig. 6 1 Wiring Diagram of VS-626MTII Drive

6.2 LEAD SIZE

Power leads and fan motor power leads are listed in Tables 6.1 and 6.2. Control signal leads and connectors are listed in Table 6.3.

Table 6.1 Power Lead Specifications

VS-626MTII Type CIMR-MTII	Input					Output			
	Lead		VS-626MTII Controller			Lead		Motor	
	Type	Size mm ²	Terminal	Terminal Screw	Terminal	Type	Size mm ²	Terminal	Terminal Screw
5.5KB	600 V cable	5.5	R, S, T, E	M8*	U, V, W, E	600 V cable	5.5	U, V, W, E	*
7.5KB		8					8		M8
11KB		14					14		M8
15KB		22					22	M10	
18.5KB		30					30	M8	
22KB		38					38		U, V, W, X, Y, Z, E
26KB									

* M5 for flange-mounted type motors and M8 for foot-mounted type motors

* VS-626MTII terminal screw is hexagon socket head bolt

Table 6.2 Cooling Fan Motor Power Lead Specifications

Application	Lead		Terminal*	Terminal Screw
	Type	Size		
Cooling fan power lead	600 V vinyl- insulated lead	2 mm ²	u, v, w, e	M4

* Since type EEVA-5IKM flange-mounted motors (5.5kW/3.7kW, 7.5kW/5.5kW) are provided with a single-phase fan motor, only terminals u and v are furnished

Table 6.3 Control Signal Lead and Connector Specifications

Connector Code	Application	Connector			Lead
		Type MR-	Manufacturer	Type	Size
1CN	I/O interface (1)	50LF			0.3 mm ² coaxial 50-core
2CN	Meter signal	16LF	Honda Tsushin	Vinyl cable* with braided copper shield	0.3 mm ² twisted lead 4-pairs
3CN	I/O interface (2)	34LF	Kogyo Co., Ltd		0.3 mm ² coaxial 20-core
4CN	Motor interface	20LF			0.3 mm ² twisted lead 4-pairs

* Except for analog signal lines, signal lines 1CN and 2CN may also be in conventional vinyl lead (0.5 mm²) for electric appliances provided the following are observed

- To minimize adverse effects of noise the signal lead and the power lead should be separately run through as short a passage as possible
- The outer diameter of the cable bundle must be smaller than the size of the connector outlet opening given below

Type MR-50LF 16mm diameter
 Type MR-16LF 9mm diameter
 Type MR-34LF 15mm diameter
 Type MR-20LF 11mm diameter

6.3 WIRING INSTRUCTIONS

Complete VS-626MTII interconnections, following the instructions given below.

(1) Control signal leads (1 to 4CN) must be separated from main circuit leads (R, S, T, U, V, W) and other power lines and power supply lines to prevent erroneous operation caused by noise interference.

(2) Use the twisted shielded lead for the control signal line, and connect the shield sheath to any of the controller terminals. See Fig. 6.2. It is recommended that the wiring distance of the signal leads be 50 meters or below. The wiring distance between a motor and a VS-626MTII unit should be 20 meters or below.

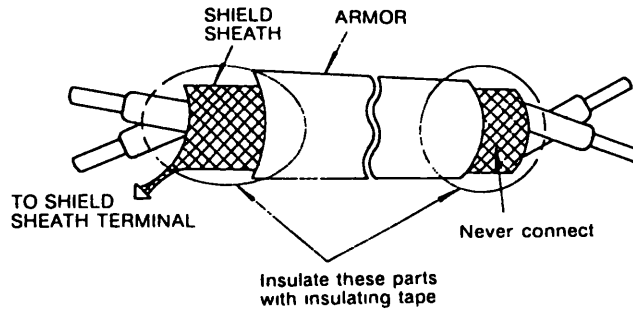

Fig 6.2 Shielded Lead Termination

(3) Make a positive grounding using ground terminal (E) on the casing of VS-626MTII.

- Ground resistance should be 100Ω or less.
- Never ground VS-626MTII in common with welding machines, motors, and other large-current electrical equipment, or ground pole. Run the ground lead in a separate conduit from leads for large-current electrical equipment.
- Use ground lead listed in Table 6.1 and make the length as short as possible.
- Even when VS-626MTII is grounded through its mountings such as channel base or steel plate, be sure to ground VS-626MTII using the ground terminal (E).
- Where several VS-626MTII units are used side by side, all the units should preferably be grounded directly to the ground poles. However, connecting all the ground terminals of VS-626MTII in parallel, and ground only one of VS-626MTII to the ground pole is also permissible (Fig. 6.3). However, do not form a loop with the ground leads.

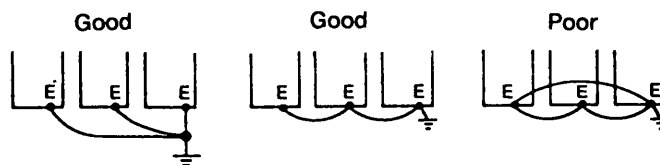

Fig. 6.3 Grounding of Three VS-626MTII Units

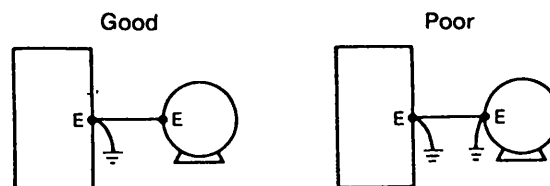

Fig 6.4 Grounding of Motor and VS-626MTII

(4) Phase rotation of input terminals (R, S, T) is available to each direction, clockwise and counterclockwise. However, if the phase rotation of motor cooling fan is reversed, the direction of air flow will also be reversed. To reverse the rotation, interchange any two of motor leads.

(5) Never connect power supply to output terminals (U, V, W).

(6) When VS-626MTII controller output terminals (U, V, W) are connected to motor terminals (U, V, W), motor rotates counterclockwise, viewed from drive end, upon forward operation command.

(7) Care should be taken to prevent contact of wiring leads with VS-626MTII cabinet, for short-circuit may result.

(8) Never connect power factor correction capacitor between the VS-626MTII controller and motor.

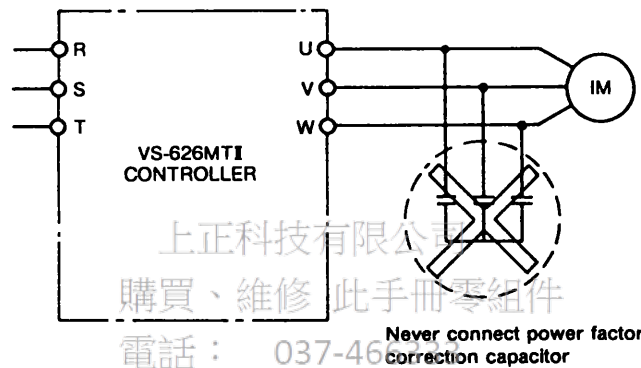

Fig. 6.5 Removal of Power Factor Correction Capacitor

(9) When several motors are connected, they must be stopped before turned on or off by means of magnetic contactors connected between the motors and VS-626MTII controllers. If the contactors are turned on or off during motor operation, an overcurrent flows through the VS-626MTII controller and overcurrent protection (OC) is activated. Repetition may damage the VS-626MTII controller.

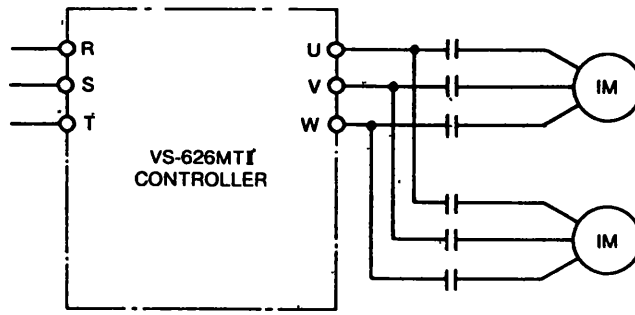

Fig. 6.6 Connections when Several Motors are connected to a VS-626MTII Controller

6.3 WIRING INSTRUCTIONS (Cont'd)

(10) When applying a ground fault interrupter or relay, it should have good balance characteristics and be connected on the power supply side as shown in Fig. 6.7. Since the output from the VS-626MTII controller contains higher-level harmonic components, a zero-phase current flows through the stray capacitor (C1) of the cable between VS-626MTII controller and motor or through the stray capacitor (C2) of the motor, sometimes resulting in erroneous operation of the ground fault interrupter. Because of this, they must be installed in accordance with the following:

- Make the cable between the VS-626MTII controller and motor as short as possible and reduce the steady state zero-phase current.
- Set rated current of the ground fault interrupter to 200 mA or more and operating time, 0.2 sec or more. (Fig. 6.8).
- Use a ground fault interrupter which is designed for inverter or is not operated by impulse waves, and set the rated sensitivity current to 30 mA.

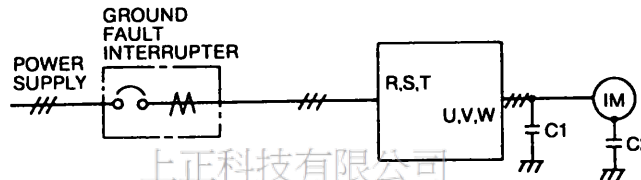

Fig. 6.7 Installation of Ground Fault Interrupter

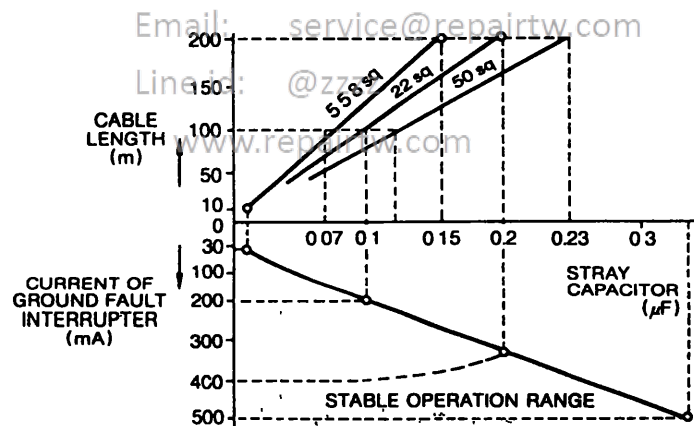

Fig. 6.8 Current Setting of Ground Fault Interrupter

(11) If both the VS-626MTII controller and magnetic contactor are placed in the same control panel, the controller may sometimes operate erroneously due to the noise generated from the coil of the magnetic contactor. Connect a surge absorber in parallel with the coil of the magnetic contactor. The surge absorber will absorb the energy stored in the coil of magnetic contactor and thus must have a capacity suited to the coil. Yaskawa's magnetic contactors and surge absorbers are shown in Table 6.4.

CAUTION

Never connect surge absorbers to the output terminals (U, V, W) of the controller.

Table 6.4 Surge Absorbers

Magnetic Contactor and Control Relay Type	Surge Absorber*		
	Type	Specifications	Code No
200V Class HI-10, -20, -25, -35, -50, -65, -80, -125 RA-6E ₂ , RL-33E Control Relay LY-2, -3 [†] HH-22, -23 [‡] MM-2, -4 [†]	DCR2-50A22E	250VAC 0.5 μ F + 200 Ω	C002417
	DCR2-10A25C	250VAC 0.1 μ F + 100 Ω	C002482
400V Class	DCR2-50D100B	1000VDC (500VAC) 0.5 μ F + 220 Ω	C002630

* Made by MARCON Electronics Co. Ltd

† Made by Omron Tateishi Electronics Co

‡ Made by Fuji Electric Co. Ltd

Note For contactors other than those listed above,
use the following surge absorbers

• For 200V class Type DCR 2-50A22E

• For 400V class Type DCR 2-50D100B

上正科技有限公司
 購買、維修 此手冊零組件
 電話： 037-466333

7. PREPARATION FOR OPERATION

7.1 CHECKS BEFORE TEST RUN

After completing mounting and connection of units, check for:

- Correct connections. Never use control circuit buzzer check.
- No loose screw terminals (Input/output terminals, fuses, parts in main circuits)
- Connectors are firmly connected to proper terminals, etc.
- No short-circuit conditions
- Operable condition of the motor, spindle and machines.

7.2 CHECKING POWER UNIT AND PRINTED CIRCUIT BOARDS

Check for appropriate types of the power unit and printed circuit boards in accordance with Table 7.1. If the type is incorrect, the specifications cannot be met. In this case, contact your Yaskawa representative.

7.2 CHECKING POWER UNIT AND PRINTED CIRCUIT BOARDS (Cont'd)

Table 7.1 Types of Power Unit and Printed Circuit Board









Name	Type						
Power Unit*	CIMR-MTII-						
	5.5KB (5.5kW)	7.5KB (7.5kW)	11KB (11kW)	15KB (15kW)	18.5KB (18.5kW)	22KB (22kW)	26KB (26kW)
Control Circuit Board	JPAC-C220						
Base Drive Circuit Board	JPAC-C221						

* Parenthesis shows motor capacity for 30-minute operation rating

7.3 SHUNT CONNECTOR SETTING

Shunt connectors shown in Table 7.2 are temporarily preset at the factory, except for those marked with "*". Therefore, the connectors must be properly selected by the user in accordance with machine specifications. Refer to Figs. 7.2 and 7.3 for the location of the shunt connectors on the printed circuit boards.

Table 7.2 Shunt Connector Setting

Function	Description
D/A converter selection	 D1 12-bit binary specifications D2 3-digit BCD specifications
Speed input selection	 N1 Analog speed command input (+10V/100%) N2 Digital speed command input (D/A converter)
Orientation command selection	 O1 Where orientation card is used O2 Orientation by NC
* Current command phase compensation	 I1, I3 Standard I2, I4 Not used
Speed coincidence detection level	 A1: Within $\pm 30\%$ (for rated speed) A2: Within $\pm 15\%$ (for rated speed)
Speedometer selection	 S1: Voltmeter (10V full scale) S2: Ammeter (1mA full scale)
Load meter selection	 L1: Voltmeter (10V full scale) L2: Ammeter (1mA full scale)
Malfunction relay mode selection	 F1: Alarm relay normally not energized F2: Alarm relay normally energized
* Regenerative current limit level selection	 A, D Units other than 11 kW unit B, C 11 kW unit only

* Shunt connectors with * are preset at the factory. Do not tamper with these connectors

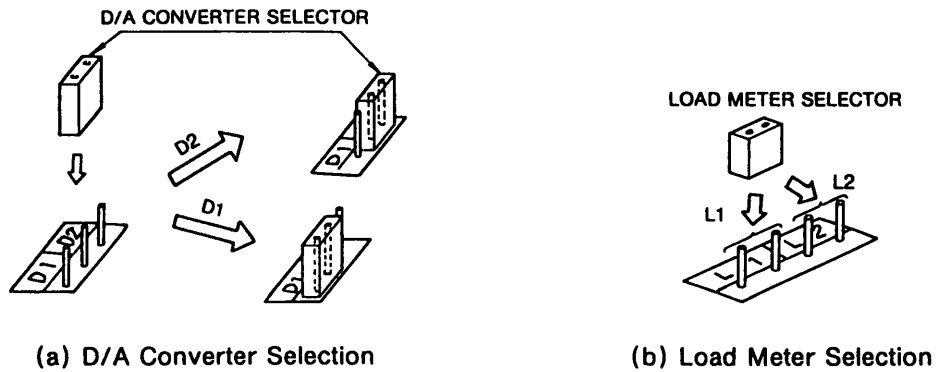

Fig. 7.1 Selection of Shunt Connector

7.4 ADJUSTMENT OF SETTING SWITCH

1DS on the control circuit board is a selector switch for rated speed. Set the rated speed in accordance with machine specifications. Also, 1 to 4 DRS on the control board and 1 to 3 DRS on base drive board are set according to the type and capacity of the motor and VS-626MTII controller. If these settings are incorrect, the protective circuit may not function as intended. Thus, it is necessary to confirm that the settings are the same as the standard settings shown in Tables 7.3 and 7.4. For the location of setting switch on the printed circuit boards, refer to Figs. 7.2 and 7.3.

Email: service@repairtw.com

Line id: @zzzz

Table 7.3 Switch Setting of Control Circuit Board

Function	Symbol	Description							
Rated Speed (rpm)	1DS	1: —	2: 4500	3: 5250	4: 6000				
Speed Controller Gain (Orientation Control)	2DS	1: —	2: P control	3: Medium	4: Low	ALL OFF: High			
Slip Frequency Setting, Flange-mounted Type (Foot-mounted Type)	Capacity (kW)	5.5	7.5	11	15	18.5	22	26	
	1DRS	8 (1)	4 (3)	9 (9)	9 (1)	1 (1)	5 (5)	0 (0)	
	2DRS	7 (8)	6 (4)	3 (3)	4 (2)	1 (1)	1 (1)	1 (1)	
Exciting Current Setting, Flange-mounted Type (Foot-mounted Type)	Capacity (kW)	5.5	7.5	11	15	18.5	22	26	
	3DRS	E (5)	E (10)	8 (8)	6 (5)	7 (7)	5 (5)	6 (6)	
	4DRS	E (5)	E (10)	8 (8)	6 (5)	7 (7)	5 (5)	6 (6)	

7.4 ADJUSTMENT OF SETTING SWITCH (Cont'd)

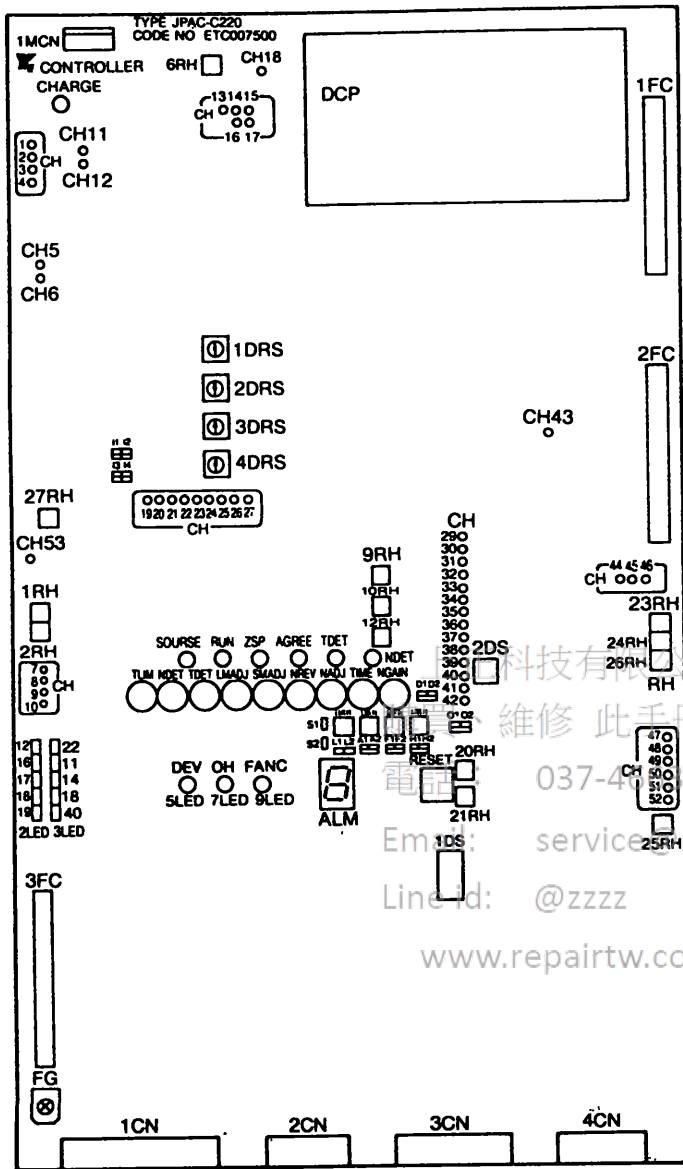

Fig. 7.2 Component Layout of Control Circuit Board

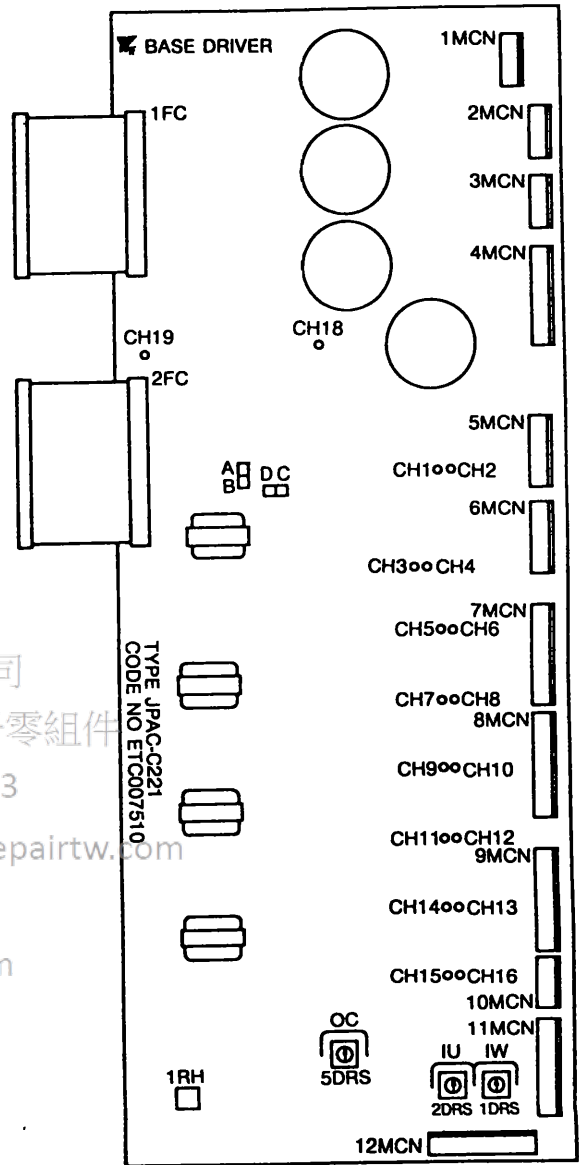

Fig. 7.3 Component Layout of Base Drive Circuit Board

Table 7.4 Switch Setting of Base Drive Circuit Board

Function	Symbol	Description						
		5.5	7.5	11	15	18.5	22	26
Current Detection Gain, Flange-mounted Type (Foot-mounted Type)	Capacity (kW)	5.5	7.5	11	15	18.5	22	26
	1DRS	6 (A)	A (B)	8 (8)	C (B)	C (C)	D (D)	E (E)
	2DRS	6 (A)	A (B)	8 (8)	C (B)	C (C)	D (D)	E (E)
Overcurrent Detection Level	Capacity (kW)	5.5	7.5	11	15	18.5	22	26
	5DRS	5	5	4	5	5	4	4

An arrow is marked on the selector switch as shown in Fig. 7.4. In the example shown in Fig. 7.4, "0" setting is shown.

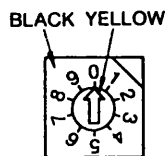

Fig 7 4 Setting Switch

7.5 CHECKING POTENTIOMETER SETTING

The potentiometers have been adjusted to appropriate level at the factory. The potentiometers other than those shown below are paint-locked. Be sure that the lock positions are not slided from the paint. Refer to Figs. 7.2 and 7.3 for the position of each potentiometer on the printed circuit boards.

- Potentiometers not paint-locked
NADJ, NREV, LMADJ, SMADJ

上正科技有限公司
 購買、維修、此手冊零組件
 電話: 887-46333

7.6 CHECKING POWER SUPPLY VOLTAGE

Confirm that the input power supply voltage is within the allowable range shown in Table 7.5.

Email: service@repairtw.com
 Line id: @zzzz

Table 7.5 Allowable Range of Power Supply Voltage

Rated Voltage V	Frequency Hz	Allowable Range V
200	50/60	170-220
220	50/60	187-242
230	60	195.5-253

Note Spindle drive system can normally operate within a range of 170 to 253V and has been set in such a manner that the optimum characteristics can be obtained between 200 and 240 V. Therefore, if the input voltage can be changed by switching the transformer taps, operation with the most desirable characteristics can be obtained by setting the input voltage within the 200 to 240V range.

8. ADJUSTMENT DURING TEST RUN

CAUTION

Observe the following precautions before turning on the power:

- Check to be sure that there is no obstacle interrupting operations.
- Before starting operation, warn the personnel nearby.

Turn on the power for VS-626MTII after securing safety around the equipment.

8.1 CHECKING AFTER POWER ON

When the power is turned on, the cooling fans of VS-626MTII and motor begin to rotate. Check the following:

8.1.1 Check of AC Spindle Motor

Check that the direction of cooling air is as shown in Fig. 8.1. If the air direction is reversed, the connections of any two of three wires to the cooling fan power supply should be reversed, as shown in Fig. 8.2. If the reverse direction of cooling air in Fig. 8.1 is required, contact Yaskawa representative.

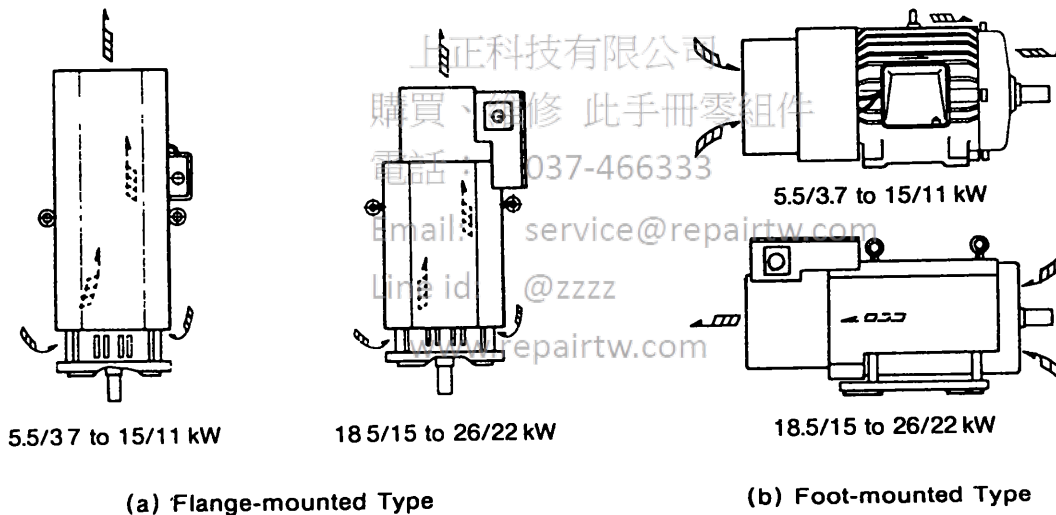

Fig. 8.1 Flow of Cooling Air of AC Spindle Motor

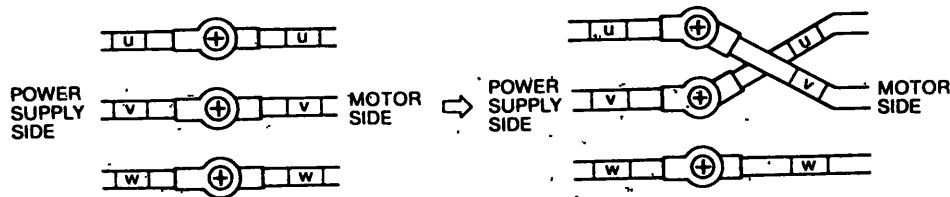

Fig 8.2 Connection Change of Motor Cooling Fan Power lead

8.1.2 Check of VS-626MTII Controller

After turning on the power, LEDs of "ZSPD", "SOURCE" and "NDET" in the central part of the printed circuit boards light (green), and "CHARGE" LED in the upper left corner will light dimly (red). If the Ready signal is closed, the input interface indicator lamp 2LED-12 lights (green) and "CHARGE" LED will light brightly (red). At this time, if the malfunction indicator lamp lights or the normal indication of LEDs, as stated above, does not occur, investigate in accordance with troubleshooting procedures. (See Figs. 9.7 to 9.16)

Tables 8.1 to 8.3 show the contents of LEDs on the printed circuit boards. Refer to Figs. 7.4 and 7.5 for the position on the printed circuit boards.

Table 8.1 Input Interface Indications

2LED	Signal	3LED	Signal
12	Ready signal (RUN SB)	22	Orientation (ORICM)
16	Forward run (FOR RN)	11	Malfunction reset (RESET)
17	Reverse run (REVRN)	14	Override cancel (ORCAN)
13	Emergency stop (EM STP)	18	Torque limit (H)
19	Soft start cancel (S SCAN)	40	Torque limit (L)

電話： 037-466333

Email: service@repairtw.com

Line id: @zzzz

Table 8.2 Status Indications

LED Code	Color	Indication	Status Description
CHARGE	Red	Power charge	Voltage applied to or remains in main capacitor
SOURCE	Green	Power supply	Power supplied to main circuit and ready to operate
RUN	Green	Motor running	Power supplied to spindle motor
ZSPD	Green	Zero speed	Spindle motor stopped or idling (below 30 rpm)
AGREE	Green	Speed coincidence	Motor speed coincides with command value ($\pm 15\%$)
TDET	Green	Torque detection	Torque command value exceeds set value
NDET	Green	Speed detection	Motor speed lower than set value
DEV	Red	Excessive speed deviation	Motor speed drops below 50% of command value

8.1.2 Check of VS-626MTII Controller (Cont'd)

• Protective Functions for VS-626MTII

If trouble occurs, the base signals to the main transistor are interrupted and the alarm signal is output as a contact signal. The alarm status is indicated by the numerical symbol on the control board, as shown in Table 8.3.

Table 8 3 Protective Functions for VS-626MTII

Alarm			Situation
No	Item	Symbol	
1	DC Fuse blown	FU	DC circuit fuse blown
2	Overcurrent Protection	OC	Detection of main transistor instantaneous overcurrent
3	MCCB* tripped	MCCB	Detection of main circuit input overcurrent
4	Overvoltage Protection	OV	Detection of DC bus overvoltage
5	Overspeed Protection	OS	Detection of motor overspeed
6	Undervoltage Protection	UV	Detection of input power supply undervoltage
7	Overload Protection	OL	Detection of motor overload current
	Overheat †	OH, FAN C	Motor or controller thermostat activates

* Molded-case circuit breaker

† If OH or FAN C activates alarm 7 is displayed and OH or FAN C lamp blinks every 1 second. However, it is a normal condition for the OH lamp to be ON during acceleration or deceleration

購買、維修 此手冊零組件

電話： 037-466333

8.2 OPERATION

After check with power on, supply a running signal to operate. Gradually increasing the speed command voltage from 0V starts the motor. Check that the direction of motor rotation is proper. The proper direction is counterclockwise as viewed from the motor shaft end when forward running signal (FORRN) is closed and the speed command has a positive polarity.

A wrong phase sequence of the power cable between VS-626MTII controller and motor or the resolver signal can be considered if the direction of rotation is reverse, or if the motor roars or vibrates, without rotating, during operation. Turn off the power and check the wiring.

Check that the motor smoothly accelerates and decelerates in both forward and reverse directions by changing the speed command. At the same time, check that the motor is not vibrating or emitting noise anomalously. The sound of the motor constantly audible at several thousand hertz is caused by the control system and presents no problem.

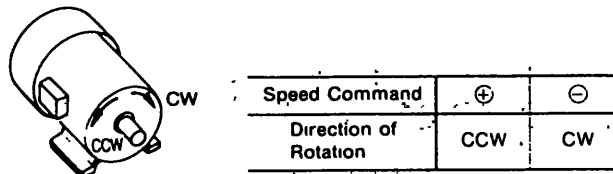
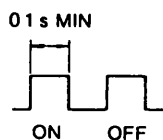

Fig 8.3 Direction of Motor Rotation

CAUTION

- Start the motor after confirming that the motor is completely stopped. If the motor is started during coasting, overvoltage (OV) or overcurrent (OC) may occur
- Do not turn on MCCB in the VS-626MTII controller after turning on the power. Tripping may occur due to the charging current to capacitors (Power supply OFF → MCCB ON → Power supply ON)
- Inching operation should be made at intervals of longer than 0.1 s since there is an interlock with the zero speed signal.



An overrun may occur if the speed command is high and inching is performed with the time shorter than 0.1 s.

8.3 ADJUSTMENT

Potentiometers on the printed circuit boards are preadjusted at the factory, So normally, readjustment is not required. However, the following potentiometers can be adjusted when needed. Table 8.4 shows the potentiometers for which the set value can be changed, depending on operation specifications. Table 8.5 shows the potentiometers for making fine adjustments for offset. Do not tamper with any potentiometers other than those stated above.

Table 8.4 Adjustable Potentiometers

Symbol	Function	Factory Setting* (graduation)
N ADJ	Speed adjustment	5
N REV	Reverse speed compensation	4
SM ADJ	Speedometer adjustment	6
LM ADJ	Load meter adjustment	7
T LIM	Torque limit level setting	0
T DET	Torque detection level	0
N DET	Speed detection level	0
N GAIN	Speed loop gain adjustment	5
TIME	Accel/Decel Time Setting	0

* Indicates approximate value.



Potentiometer is set at 5th graduation

8.3 ADJUSTMENT (Cont'd)

Table 8 5 Potentiometers for Offset Adjustment

Code	Function	Factory Setting (graduation)
16RH	Speed reference (orientation control)	4-6
17RH	Speed reference	4-6
21RH	Speed controller	5-7
24RH	Speed detection	3-5



Potentiometer is set at 5th graduation

8 3.1 Adjustment of Motor Speed (NADJ, NREV)

Readjust as instructed in the following when a fine adjustment of the absolute value of the spindle speed (motor speed) is required.

1. Rotate the motor in the forward direction, measure the speed command voltage by a voltmeter and set it to the command voltage of the desired speed.
2. Measure the speed by a tachometer after the command voltage is adjusted.
3. Rotate NADJ clockwise if the speed does not reach the rating. Adjust NADJ until the desired speed is obtained.
4. Rotate NADJ counterclockwise if the speed exceeds the rating.
5. Run the motor in reverse direction and adjust NREV so that the rated motor speed is obtained. Turning NREV clockwise increases motor speed. The characteristics of speed-setting scale is shown in Fig. 8.4.

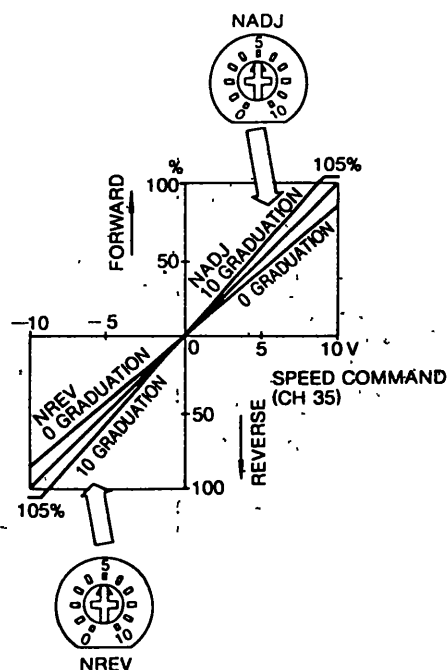

Fig. 8 4 Speed — Setting Scale Characteristics

8.3.2 Adjustment of Speedometer (SMADJ)

This is for fine adjustments of the speedometer. The potentiometer is set to output 1 mA at the rated speed at the factory. Adjust as instructed in the following if the output deviates.

1. Set SMADJ to graduation 0.
2. Set the speed command to the rated speed and make adjustments so that the speedometer shows the command value. When using a voltmeter (internal impedance of 10 kΩ) as a speedometer, select shunt connector S1 of the speedometer and make adjustments as stated above.

8.3.3 Adjustment of Load Meter (LMADJ)

This is for fine adjustments of the load meter. The potentiometer is set to output 1 mA at 120% of the rating for 30 minutes at the factory. Adjust as instructed in the following if the output deviates.

1. Set LMADJ to graduating 0.
2. Set TIME to graduation 0.
3. Set the speed command to the rated speed, and accelerate and decelerate exactly by switching on and off the forward running signal.
4. Adjust the load meter so that its needle indicates the setting scale during rapid acceleration. When using a voltmeter (internal impedance of 10 kΩ) as a load meter, select shunt connector L1 of the load meter and make adjustments by the procedures stated above. Specifications of the load meter setting scale are shown in Fig. 8.5.

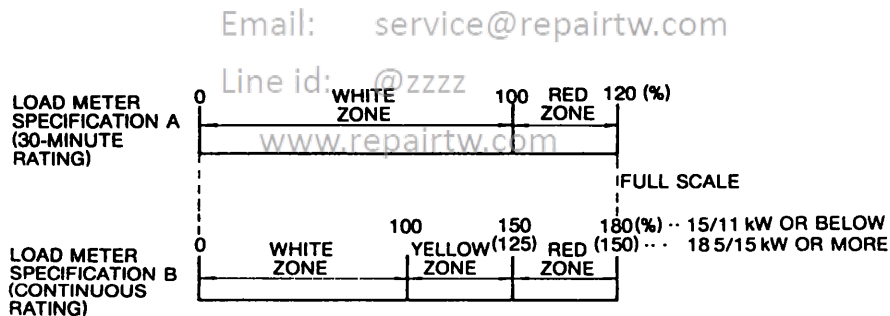

Fig. 8.5 Specifications of Load Meter Scale

Table 8.6 Load Meter Setting

Motor Capacity kW	Continuous Rating %	30-minute Rating %
5.5/3.7	178	120
7.5/5.5	164	120
11/7.5	176	120
15/11	164	120
18.5/15	148	120
22/18.5	143	120
26/22	142	120

8.3.4 Adjustment of Torque Limit (TLIM)

This is for adjusting the limit level for the torque generated by the motor. Normally, the torque limit level is set at 120% of the rating for 30 minutes. The torque limit level can be adjusted externally by TLIMH (1CN-18) or TLIML (1CN-40) and potentiometer TLIM.

1. Close the torque limit signal TLIMH or TLIML. If TLIMH and TLIML signals are closed simultaneously, TLIML signal is sent ahead prior to TLIMH signal.
2. Set TLIM to graduation 0.
3. Set the speed command to the rated speed and accelerate and decelerate exactly by switching on and off the forward running signal.
4. Adjust the load meter so that its needle indicates the desired scale during rapid acceleration.

Fig. 8.6 shows torque limit—setting characteristics.

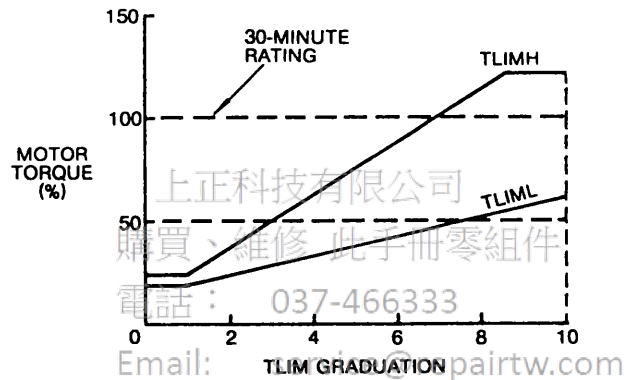

Fig. 8.6 Torque Limit—Setting Characteristics

8.3.5 Adjustment of Speed Coincidence Detection Level (N DET)

This is used for adjustment of speed coincidence detection level. While motor speed is adjusted with speed commands, NDET lights at a preset speed which is selected with the N DET. Fig. 8.7 shows characteristics of speed coincidence detection level and setting.

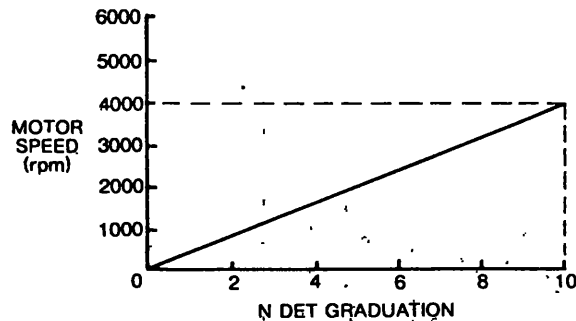

Fig. 8.7 Characteristics of Speed Coincidence Detection Level—Setting

8.3.6 Adjustment of Torque Detection Level (T DET)

This is used for adjustment of torque detection level. Adjust the T LIM by the method described in Par. 8.3.4, Adjustment of Torque Limit (T LIM) to the torque detection level. Then, while accelerating the motor, adjust the T DET so that the T DET LED lights at the required level. Fig. 8.8 shows characteristics of torque detection level and setting.

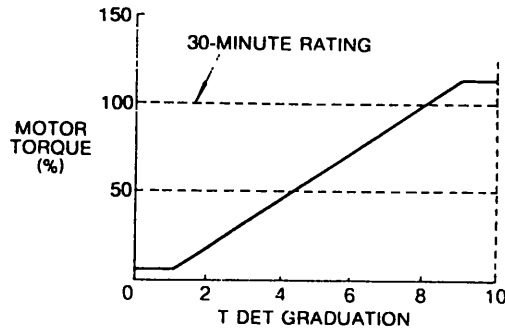

Fig 8.8 Characteristics of Torque Detection Level—Setting

8.3.7 Adjustment of Loop Gain of Speed Control System (N GAIN)

This is used for adjustment of loop gain of speed control system. The closer the setting is brought to the graduation 0, the lower and more stable the gain becomes, but the slower becomes the response. The nearer the setting is adjusted, the quicker becomes the response, but the larger becomes the speed overshooting. Adjust it to the optimum gain, taking into consideration the load conditions.

- Adjustment before shipment: Graduation 5

8.3.8 Adjustment of Accel/Decel Time (TIME)

This is for adjusting the soft start time. Adjust the soft start time in accordance with the soft start characteristics shown in Fig. 8.9.

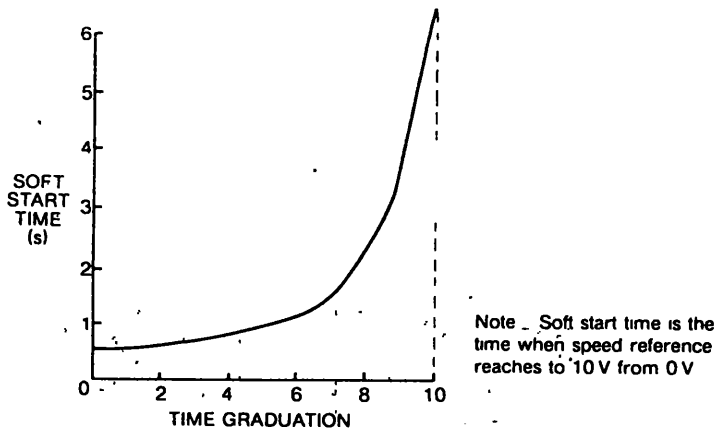

Fig 8.9 Soft Start Time—Setting Characteristics

8.3.9 Offset Adjustment of Speed Control System

Offset adjustment of the speed control system during orientation should be performed using the following procedures:

Table 8 7 Offset Adjustment of Speed Control System

Item	Speed Command	Speed Detection Signal
Check Terminals	CH40-CH43 (0V)	CH45-CH43 (0V)
Potentiometers	16RH	23RH
Allowable Value	± 5mV max	± 5mV max
Condition	Adjust when speed command (CH35) is 0V	Adjust when the motor is completely stopped

Note After adjustment, perform the orientation operation and if the position has deviated make an offset adjustment (21RH) for the speed controller

9. MAINTENANCE

VS-626MTII requires almost no routine checks, but regular periodical maintenance is necessary to maintain normal and smooth operating conditions. Formulate a maintenance schedule after studying the maintenance items shown below.

電話： 037-466333

CAUTION

Do not touch the inside components of VS-626MTII for 5 minutes after turning off the power supply. Before servicing inspection, check that the smoothing capacitors have been completely discharged. This can be verified by the "CHARGE" lamp on the panel being off.

9.1 DAILY INSPECTION ITEMS

For the spindle motor, daily inspection of the following items should be performed:

- Rated speed is correct.
- Cooling fan rotates smoothly.
- Cooling air circulates normally.
- Any abnormal vibration.
- Any abnormal sound.
- Any abnormal odor.

VS-626MTII requires almost no routine checks since it has been designed with highly reliable circuit technology and is comprised mostly of semiconductors, such as ICs and power transistors.

9.2 PERIODIC INSPECTION

To maintain the AC spindle motor and VS-626MTII in good operating order, perform periodical inspection and maintenance referring to Table 9.1.

Table 9.1 Periodic Inspection Items and Description

Item	Check	Corrective Action
AC Spindle Motor	Cooling Fan <ul style="list-style-type: none"> Any abnormal sound or vibration Cumulative operating time exceeds 20,000 hours 	Replace cooling fan
	Motor Bearing <ul style="list-style-type: none"> Any abnormal sound High temperature 	Contact Yaskawa representative
	Cooling Air, Inlet Port, Exhaust Port, Air Passage <ul style="list-style-type: none"> Coating of dust or cutting oil 	Clean approximately once every 6 months or more frequently, depending on operation conditions (Coating of dust or cutting oil in air passage may decrease cooling efficiency and cause malfunctions)
VS-626MTII Controller	External Terminals, Unit MTG Bolts, Connectors, etc <ul style="list-style-type: none"> Loosened screws 	Tighten
	Cooling Fan <ul style="list-style-type: none"> Any abnormal sound or vibration Cumulative operating time exceeds 20,000 hours. 	Replace cooling fan.
	Printed Circuit Board <ul style="list-style-type: none"> Discoloration to brown 	Replace the board
	Smoothing Capacitor <ul style="list-style-type: none"> Discoloration or odor 	Replace the capacitor or inverter unit
	Air Filter (Control panel) <ul style="list-style-type: none"> Coating of dust 	Clean once a month
	Electronic Parts <ul style="list-style-type: none"> Coating of dust 	Remove dust periodically.
	Regenerative Resistors, Heat Sink (on the Rear of VS-626MTII Controller) <ul style="list-style-type: none"> Coating of dust 	Remove dust with air blower or a dry cloth once every 6 months or more frequently, depending on operation conditions (Dust accumulated on regenerative resistors or heat sink may decrease radiating efficiency and cause malfunctions)

9.2.1 Prolonged Storage

If VS-626MTII is installed as a standby unit, etc., and left out of operation for a long period of time, check its operation at least once every six months by turning on the power supply.

Reformation is necessary for electrolytic capacitors if they have not been used for a long time (more than 1 year). Reformation can be accomplished in the following way:

1. Turn off the Ready signal, then turn on the power. ("CHARGE" lamp (red) lights dimly.)
2. After 5 minutes, turn on the Ready signal. ("CHARGE" lamp (red) lights brightly.)
3. Let the controller stand (as stated above) for 30 minutes.

9.3 CHECKING POWER SEMICONDUCTOR ELEMENTS

CAUTION

Do not touch the inside components of VS-626MTII for 5 minutes after turning off the power supply. Before servicing inspection, check that the smoothing capacitors have been fully discharged. This can be verified by the "CHARGE" lamp on the panel being off.

When checking or replacing parts, observe the following:

- When disconnecting leads from parts, mark them to avoid wrong connection.
- When reconnecting leads to the parts, tighten them with the specified screws firmly. If only one screw is loose, or not present, the VS-626MTII system will not operate properly.

9.3.1 Transistor Module

Checking Method

1. Unplug the nine emitter-base-collector connectors (1 to 9MCN) from base drive board. See Fig. 9.1.
2. Check the resistance value at the terminals shown in Table 9.2.

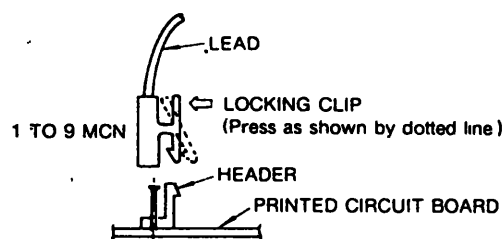

Fig. 9.1 Removal of Connectors

Table 9.2 Resistance of Transistor Modules

VS-626MTII Type CIMR-MTII-□	Transistor Module Terminals		Reference Resistance	Abnormal Resistance	Transistor Module
	Ohmmeter Terminal ⊖	Ohmmeter Terminal ⊕			
5 5KB 7 5KB	E	B	*	0 Ω or ∞	
	E	C	†	0 Ω or ∞	
	B	E	+	Approx multiple of 10 kΩ or above	
	C	E	‡	0 Ω	
	B	C	—	—	
	C	B	—	—	
11KB 15KB 18 5KB 22KB 26KB	E1 C2	C1	†	0 Ω	
	C1	E1 C2	‡	0 Ω	
	B1	E1 C2	+	Approx multiple of 10 kΩ	
	E1 C2	B1	*	0 Ω or ∞	
	E2	E1 C2	†	0 Ω	
	E1 C2	E2	‡	0 Ω	
	B2	E2	+	Approx multiple of 10 kΩ	
	E2	B2	*	0 Ω or ∞	

* Several hundred Ω to several kΩ
 † Approximate multiple of 10 Ω
 ‡ Several hundred of 1 kΩ
 Note 1 Use the ohmmeter set at × 1 Ω range
 Note 2 With type CIMR-MTII-7 5KB, measurement of the resistances across B-C and C-B are not required

Email: service@repairtw.com

Line id: @zzzz

www.repairtw.com

9.3.2 Diode Module

Checking Method

Measure the resistance at the points listed in Table 9.3, with an ohmmeter.

Table 9.3 Resistance of Diode Module

Tester Terminals	⊖	⊕	Reference Resistances	Abnormal Resistances
Diode Module Terminals 	①	②	∞	Approximate multiple of 10 Ω or below
	①	③		
	②	①	Approximate multiple of 10 Ω or below	∞ or 0 Ω
	③	①		

Note Use the ohmmeter set at × 1 Ω range to measure the resistance value

9.3.3 Thyristor Module

Checking Method

Measure the resistance at the points listed in Table 9.4.

Table 9.4 Resistance of Thyristor Module

Tester Terminals	Reference Resistances	Abnormal Resistances
	① ②	∞
	③ ①	
	② ①	
	① ③	*
	② ③	
	① ②	
① ②	†	Other than †
② ①		

* Approximate multiple of 10 Ω to several hundred Ω

† Several Ω to two hundred Ω

Note Use the tester set at × 1 Ω range

9.4 REPLACEMENT OF PRINTED CIRCUIT BOARDS

CAUTION

Do not touch the inside components of VS-626MTII for 5 minutes after turning off the power supply. Before servicing inspection, check that the smoothing capacitors have been fully discharged. This can be verified by the "CHARGE" lamp on the panel being off.

If the printed circuit boards are replaced, see Table 10.1, contact Yaskawa representative with parts name, parts code No. and quantity.

For potentiometers are adjusted according to specifications (Table 8.4), and may be readjusted as necessary.

CAUTION

Do not replace (or remove) the printed circuit boards when power supply is ON since the parts of the circuit may be damaged.

9 4 1 Replacement of Control Circuit Board

(1) Removal Procedures (Fig. 9.2)

1. Turn off the power supply and disconnect all the leads from the control circuit board (PCB) (1CN to 4CN, 1FC, 2FC and ground lead)
2. Remove the seven PCB mounting screws (M4).
3. Hold each head of the eight PCB supports with round-nose pliers and remove the supports from the guide holes in the PCB.
4. Holding the PCB at the top and the bottom by hands, lift it slightly upward and then pull it out.

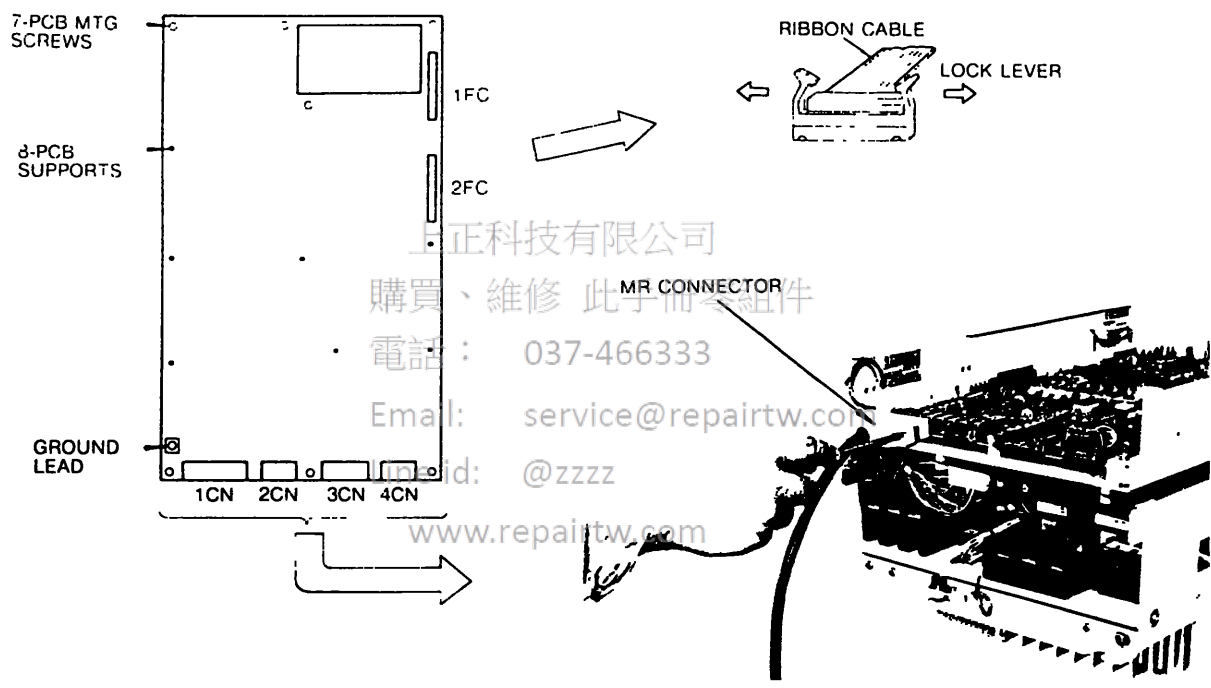

Fig 9.2 Removal of Control Circuit Board

(2) Mounting Procedures

1. Insert the control circuit board in eight PCB supports until it comes fully to the checking groove in the supports.
2. Secure the PCB to the PCB mounting board with screws at seven positions.
3. Connect the cables to the connectors.
4. Check the setting of the PCB and start operation. See Fig. 6.1.

9.4 2 Replacement of Base Drive Board

The board is mounted on the reverse side of the PCB mounting board.

(1) Removal Procedures (Fig. 9.3)

1. Turn off the power supply and disconnect all the leads from the base drive board. (1MCN to 12MCN)
2. Remove the five PCB mounting screws (M4).
3. Hold each head of the six PCB supports with round-nose pliers and remove the supports from the guide holes in the PCB. (Fig. 9.4)

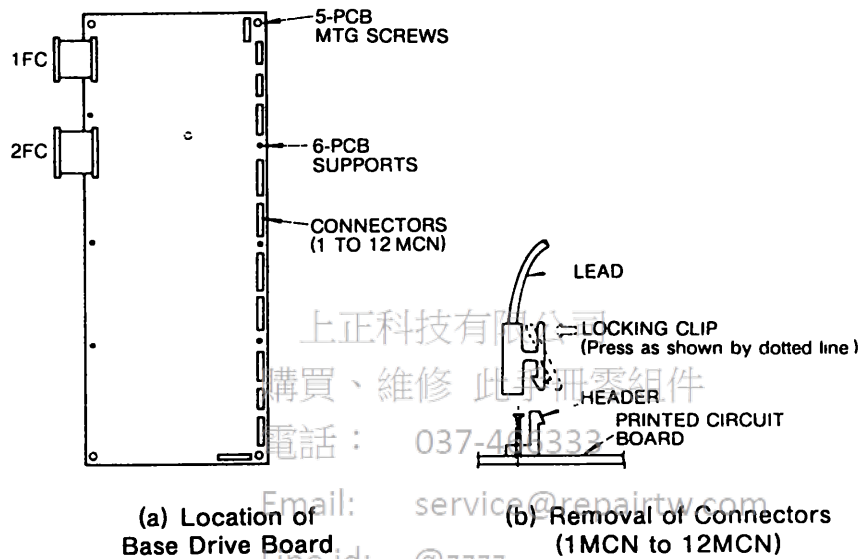

Fig. 9.3 Removal of Base Drive Board

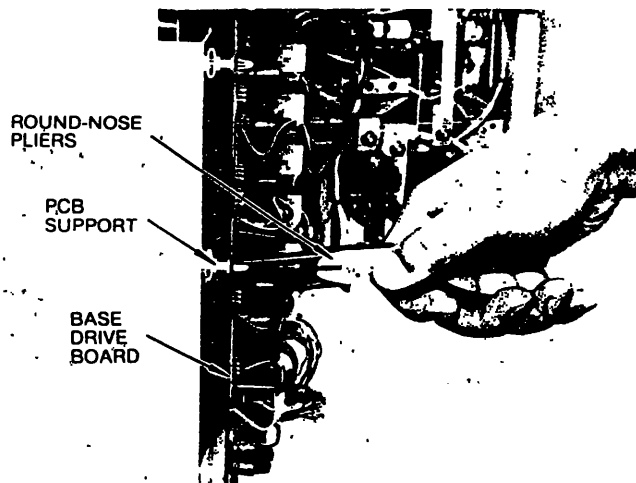

Fig. 9.4 Holding Head of PCB Support with Round-nose Pliers

(2) Mounting Procedures (Fig. 9.5)

1. Insert the base drive board in six PCB supports until it comes fully to the checking groove in the supports.
2. Secure the PCB to the PCB mounting board with screws at five positions.
3. Connect the cables to the connectors.
4. Check the setting of the PCB and start operation. See Fig. 6.1.

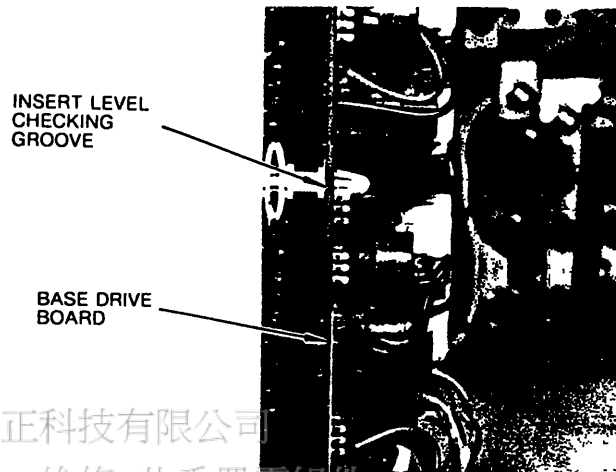

Fig 9.5 Mounting of Base Drive Board

上正科技有限公司
購買、維修 此手冊零組件

685-368

9.4.3 Replacement of Power Module 037-466333

Email: service@repairtw.com

NOTE

- When disconnecting leads or bus bars from parts, mark them to avoid wrong connection.
- When reconnecting leads to the parts, tighten them with the specified screws firmly. If only one screw is loose, or not present, the VS-626MTII system will not operate properly.

(1) Removal Procedures

1. Remove the bus bar mounting screws and the terminal screws.
2. Remove bus bars.
3. Remove all the leads from transistor and thyristor module terminals.
4. Remove power module mounting screws.
5. Remove the power modules.

(2) Mounting Procedures

CAUTION

When remounting thyristor or transistor modules, apply thermal compound "JOINTAL Z" (Nippon Light Metal Co., Ltd), or equivalent compound to the mounting surface, to assure good contact and heat conduction between the module and the mounting surface for cooling.

Install the power module in accordance with the layout plan.

9.4.4 Replacement of DC Fuses

Remove mounting bolts with a hexagonal wrench and replace the fuse.

9.4.5 Replacement of Cooling Fan

The VS-626MTII controller has a built-in fan for cooling heat sinks. Replace the fan by referring to Fig. 9.6 when the cumulative operating time of the fan reaches approximately 20,000 hours.

1. Remove the fan junction terminal screw "a" and remove the lead wire.
2. Remove screw "b" (retaining the fan case and side panel), gently raise the fan case, and remove the fan case from the side panel.
3. Remove screws "c" (at 2 places) and remove the fan from the fan support.
4. Reverse the order for reassembling the cooling fan. In this case, the fan must be installed in the proper direction (arrow "AIR" should be pointed upward.).

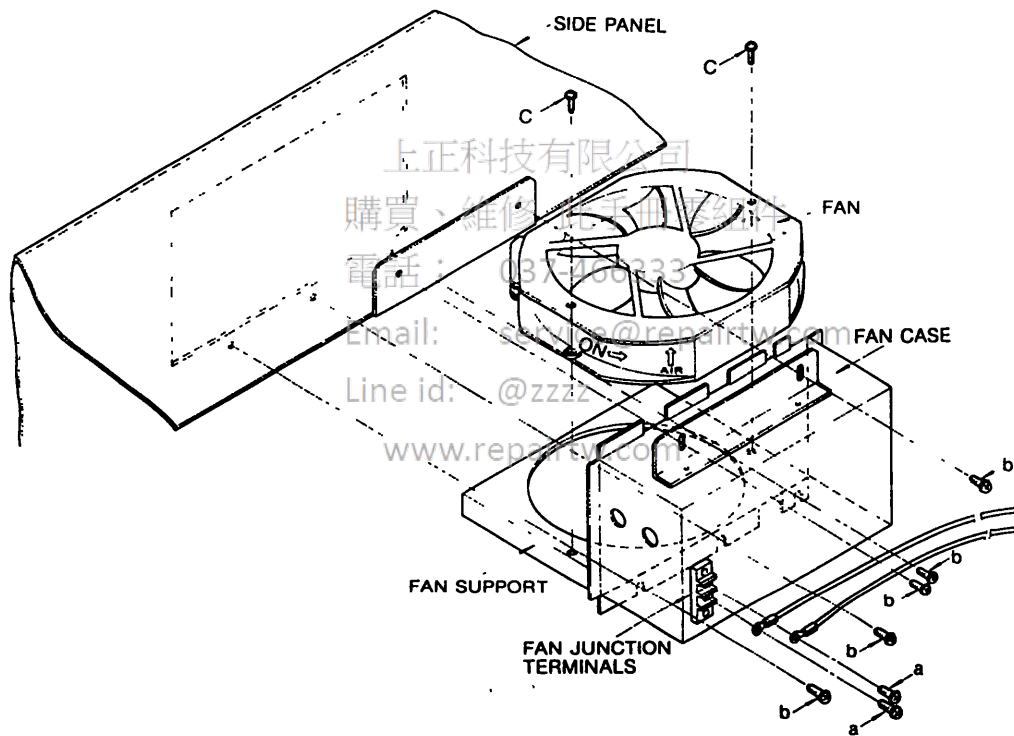

Fig. 9.6 Replacement of VS-626MTII Cooling Fan

9.5 TROUBLESHOOTING

If the VS-626MTII malfunctions, find the cause and take the corrective action by following the flowcharts given in Tables 9.5, 9.6 and Figs. 9.7 to 9.16. If any other problem occurs, contact Yaskawa representative.

Table 9.5 VS-626MTII Check Terminals and Their Signals





Check Terminal	Content	Signal	Remarks
1	Control power supply (+15 V)	$\pm 15 \pm 0.1 \text{ V}$	—
2	Speed pulse	 -5 V 0 V 3.6 kHz	fCH2 (kHz) = $0.6 \times N$ (rpm), at 6000 rpm
4	0 V	0 V	—
5	Primary frequency command (α)	 $-58 \text{ V} \pm 0.2 \text{ V}$ $-22 \text{ V} \pm 0.2 \text{ V}$ T 20 ms	At 1500 rpm, 30-minute operation rating
6	Primary frequency command (β)		
8	Speed controller output	$\pm 4 \text{ V}/100 \%$	For 30-minute rating
10	Torque command	$\pm 4 \text{ V}/100 \%$, 4.8 V max	For 30-minute rating
11	Control power supply (-15 V)	$-15 \text{ V} \pm 0.25 \text{ V}$	—
12	Control power supply (+5 V)	$+5 \text{ V} \pm 0.25 \text{ V}$	—
15	Speed monitor	$+10 \text{ V} \pm 0.2 \text{ V}$	At 6000 rpm, forward and reverse running
18	0 V	0 V	—
19	0 V	0 V	—
20	Exciting current command (β)	 $V_p = +39 \pm 0.2 \text{ V}$ T - 20 ms	At 1500 rpm, 30-minute operation rating
24	Exciting current command (α)		
23	Field control signal	$+8.7 \text{ V} \pm 0.2 \text{ V}$	At 0 to 1500 rpm, 50 to 100 % load
25	Secondary current command (α)	 $V_p = +16 \text{ V} \pm 0.1 \text{ V}$ T - 20 ms	At 1500 rpm, 30-minute operation rating
28	Secondary current command (β)		
26	Primary current command (β)		—
27	Primary current command (α)		—
22	Current detection signal (α)		—
30	Current detection signal (β)		—
29	Speed reference	$+10 \text{ V}/6000 \text{ rpm}$ (forward running)	—

Table 9 5 VS-626MTII Check Terminals and Their Signals (Cont'd)

Check Terminal	Content	Signal	Remarks
31	PWM command (U)		-
33	PWM command (V)		
34	PWM command (W)		
32	PWM carrier frequency	 $f = 31 \text{ to } 35 \text{ kHz}$	At 0 to 1500 rpm
35	Speed command	+ 10 V/100 %	-
40	Speed reference (orientation control)	+ 8 V/600 rpm (forward running)	-
41	Load meter signal	+ 4 V	At 30-minute operation rating
42	Speedometer signal	+ 5 V	At 6000 rpm
43	0 V	0 V	-
44	DC voltage detection	+ 1 V	For change of main circuit DC voltage, 10V
45	Speed detection signal	At normal operation, - 10 V/6000 rpm (reverse running) At orientation, - 8 V/600 rpm (reverse running)	-
46	0 V	0 V	-
47	Control power supply (+12 V)	+ 12 V \pm 0.05 V	-
48	Control power supply (-12 V)	- 12 V \pm 0.25 V	-
49	0 V	0 V	-
50	Resolver excitation signal (β)	 $f = 18 \text{ kHz}$ $V_{pp} = +16 \text{ V} \pm 2 \text{ V}$	-
51	Resolver excitation signal (α)		
52	Resolver detection signal	 $f = 18 \text{ kHz}$ $V_{pp} = +3 \text{ V} \pm 0.3 \text{ V}$	At stop
53	Control power supply (-7 V)	- 6.5 V \pm 0.5 V	-

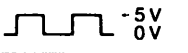
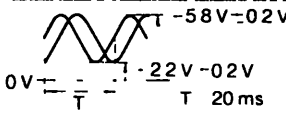
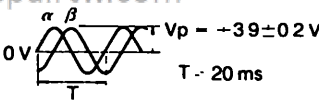
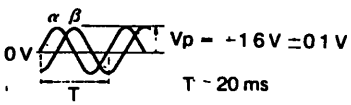
Table 9.6 Check Terminals of Base Drive Board and Their Signals

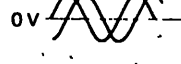
Check Terminal	Content	Signal	
1	Regeneration transistor base signal	1 • Motor Mode 0V 	
2			
3		2 • Regeneration Mode 0V 	
4			
5	Main transistor base signal	WP	
6			
7		WN	
8			
9		• At base block 0V 	
10		VP	
11			• In operation 0V 
12		VN	
13		UP	
14			
15			
16			
18		Base drive board power supply output waveform	0V 
19			

上正科技有限公司
 維修 此手冊零組件
 電話: 037-466333
 Email: service@repairtw.com
 Line id: @zzzz
 www.repairtw.com

(1) Alarm "1" (FU) lights.

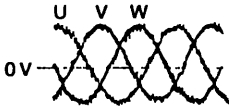
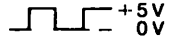
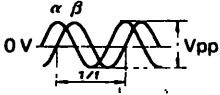
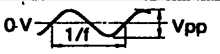
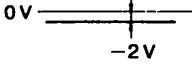
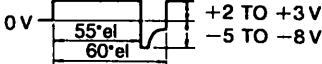
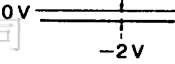
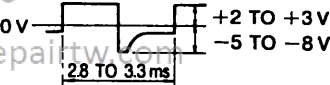
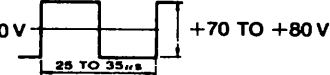
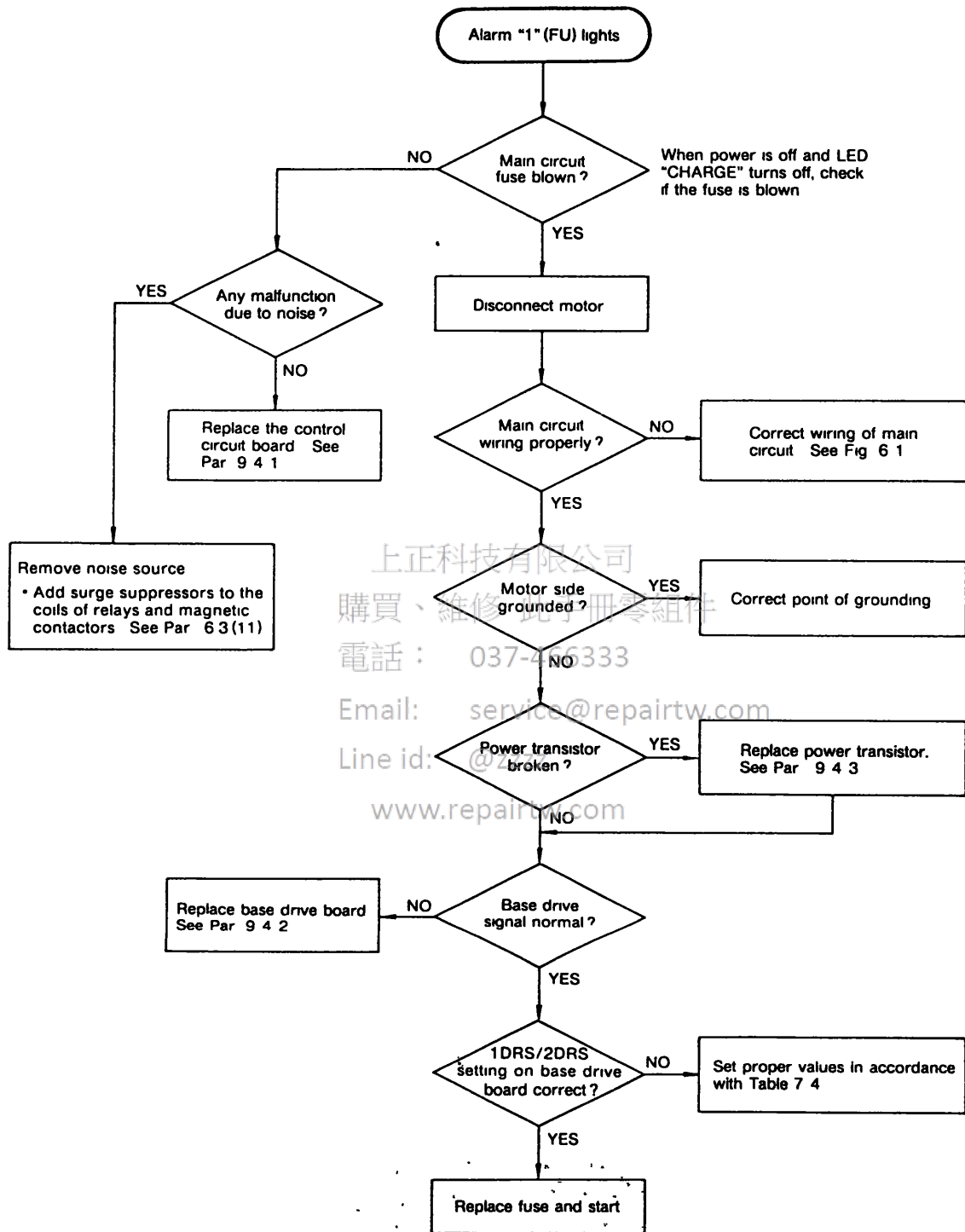

Fig. 9.7 Alarm "1" (FU)

(2) Alarm "2" (OC) lights

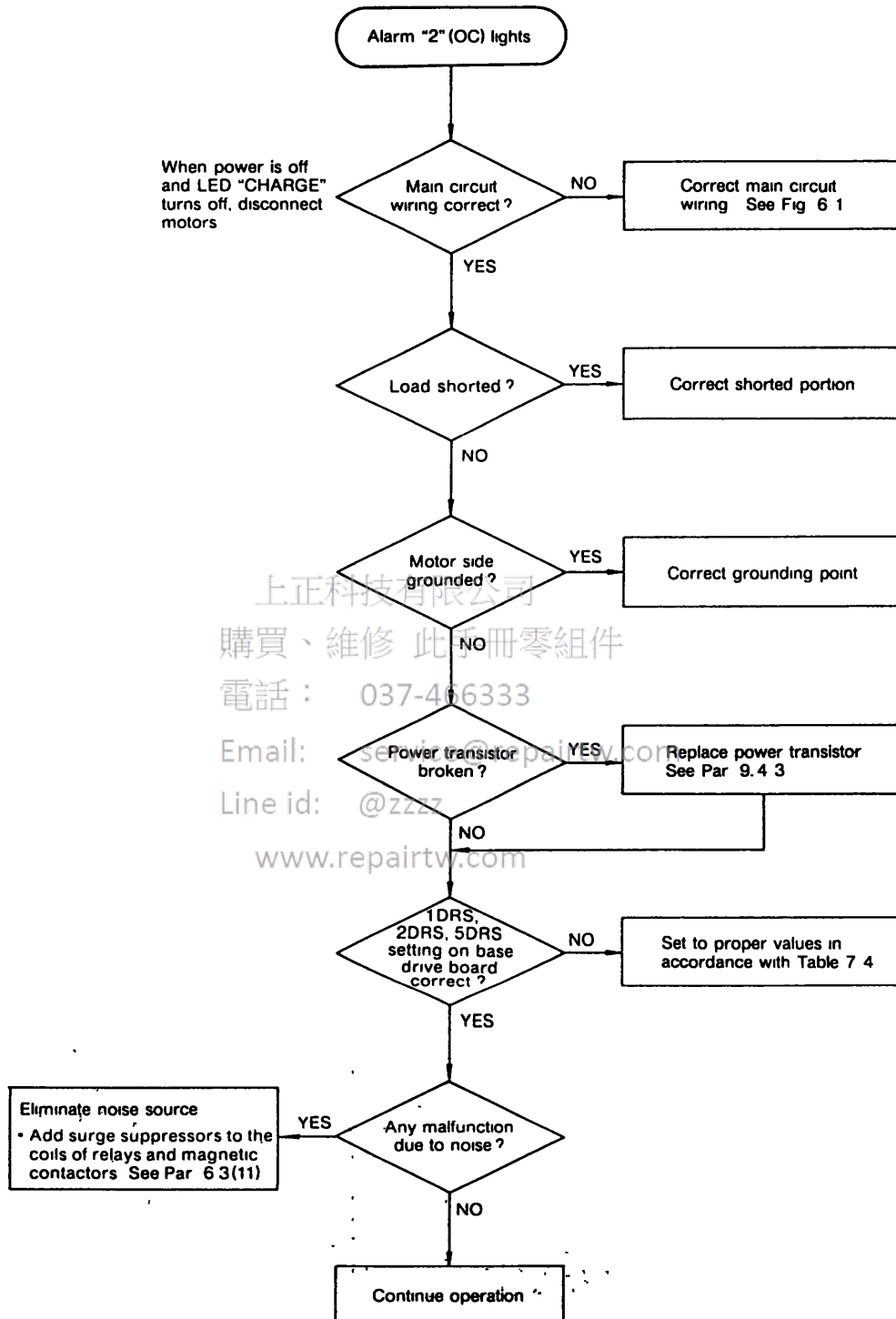

Fig. 9.8 Alarm "2" (OC)

(3) Alarm "3" (MCCB) lights.

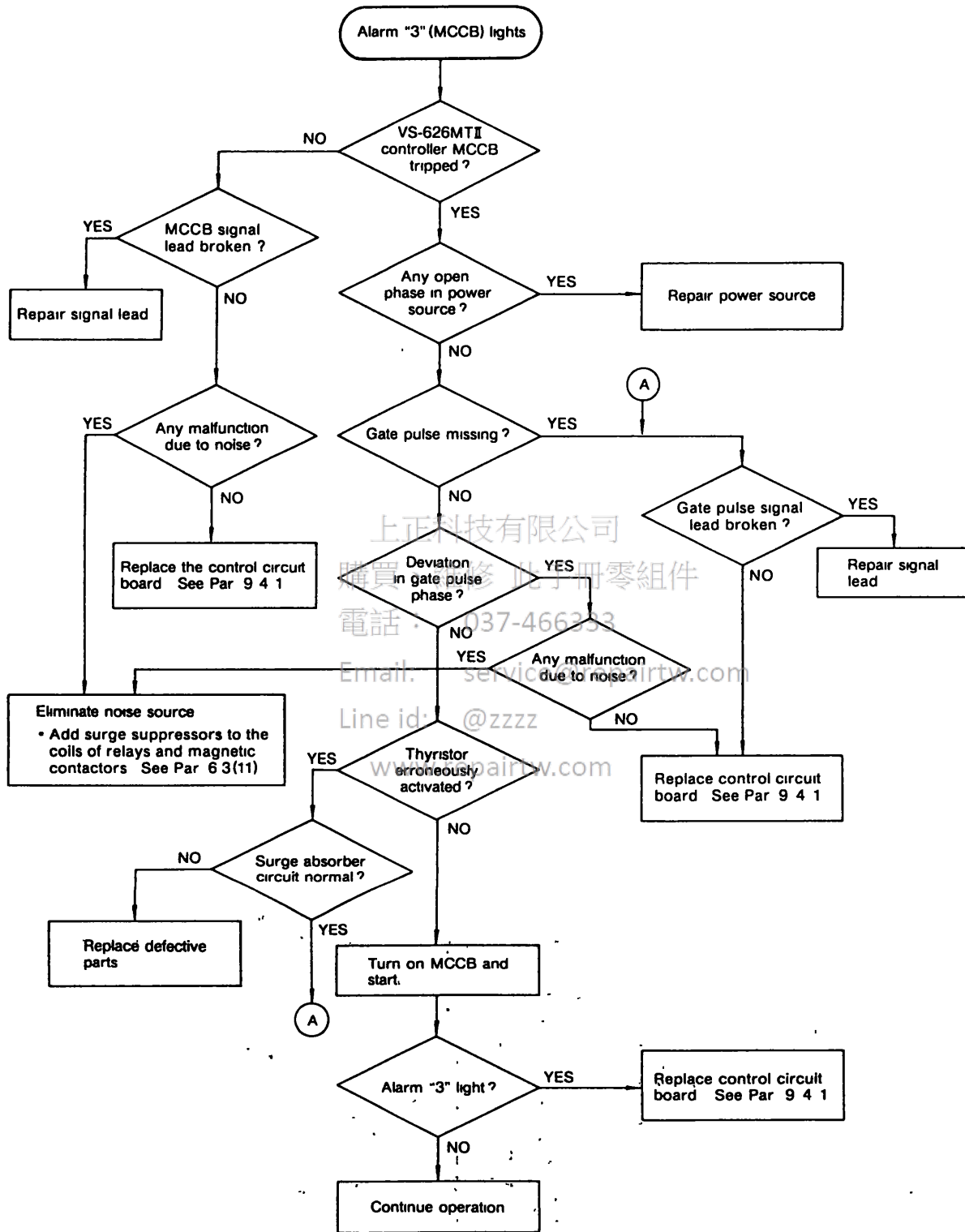

Fig 9 9 Alarm "3" (MCCB)

(4) Alarm "4" (OV) lights.

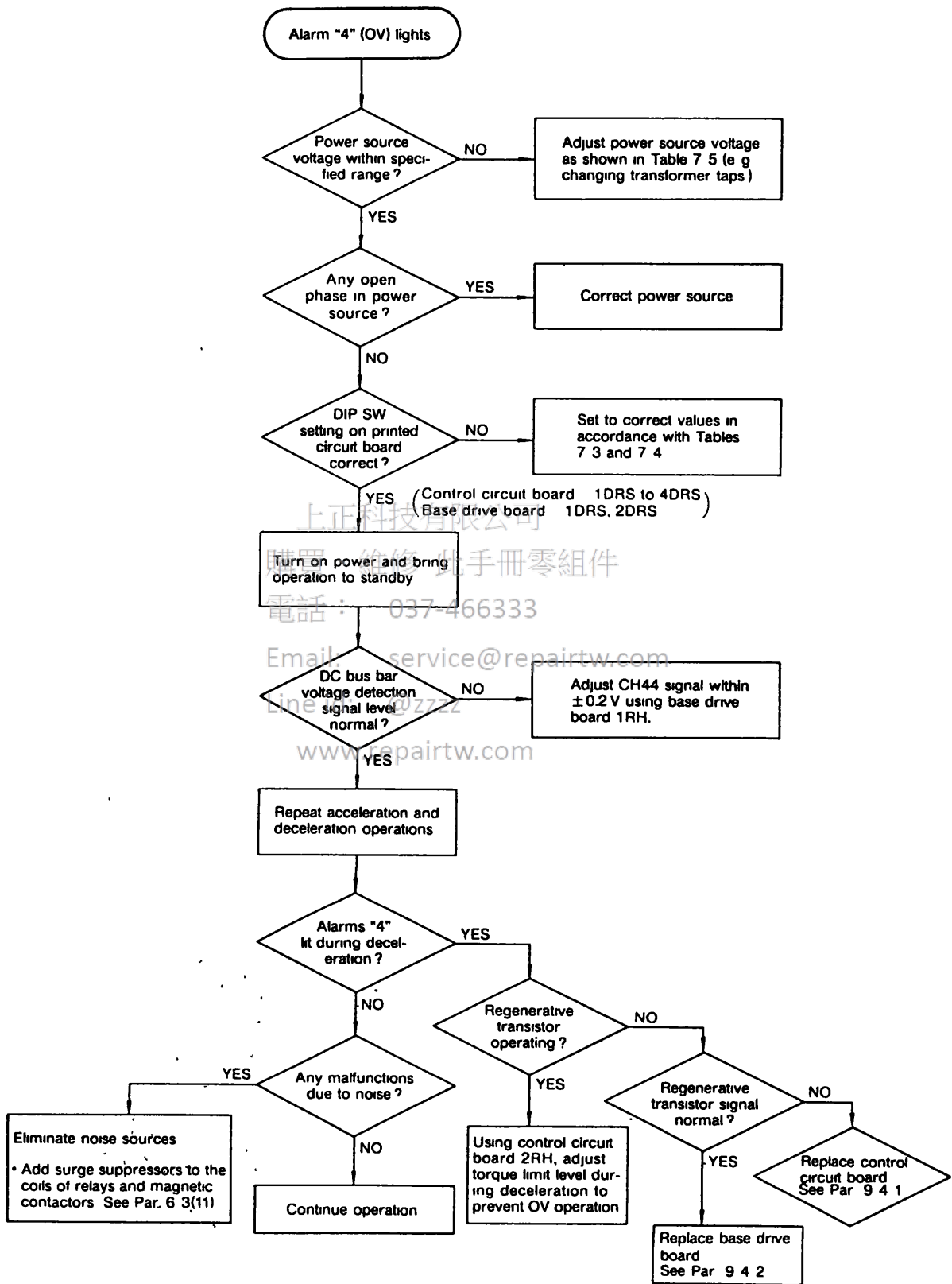

Fig. 9.10 Alarm "4" (OV)

(5) Alarm "5" (OS) lights.

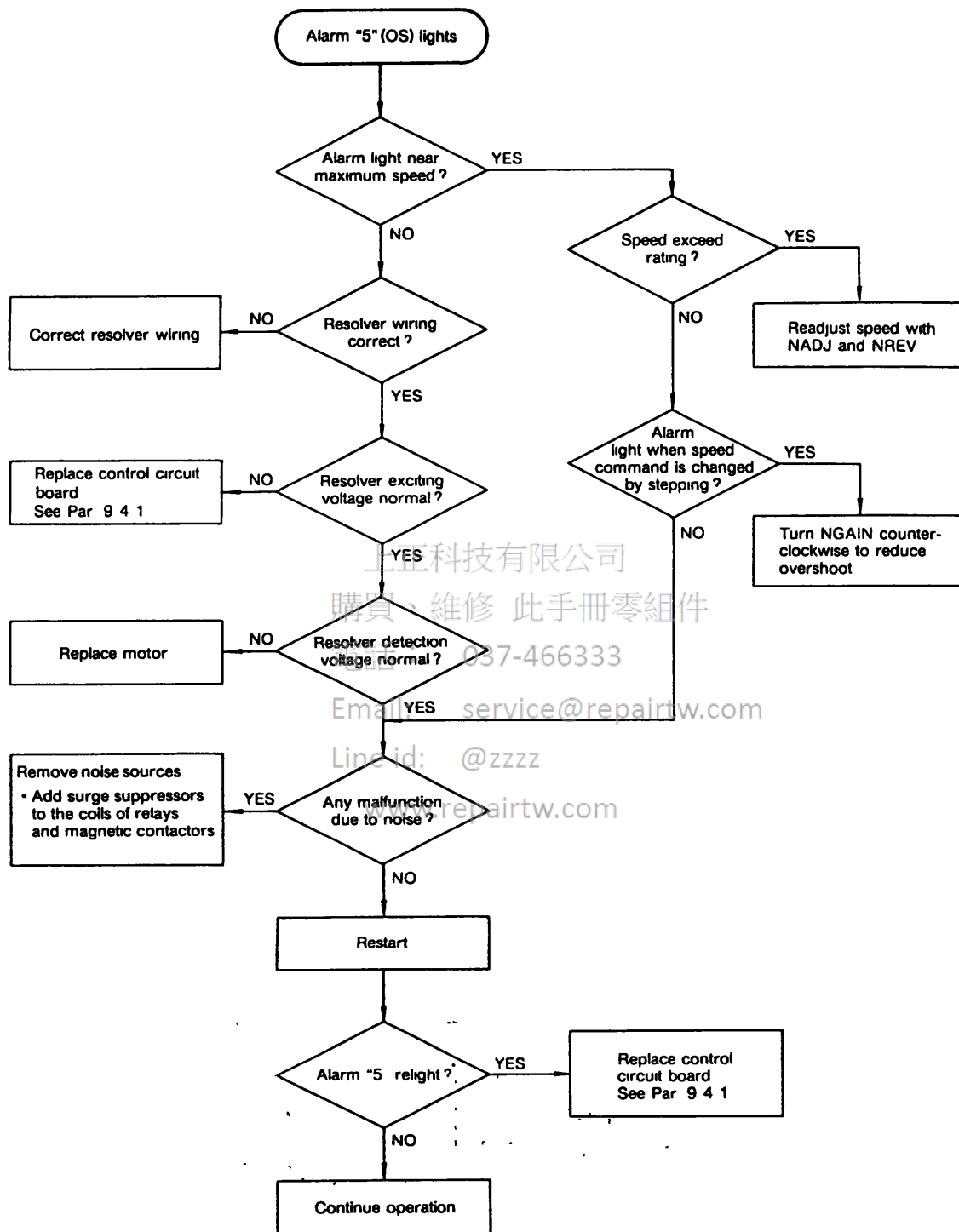

Fig. 9.11 Alarm "5" (OS)

(6) Alarm "6" (UV) lights

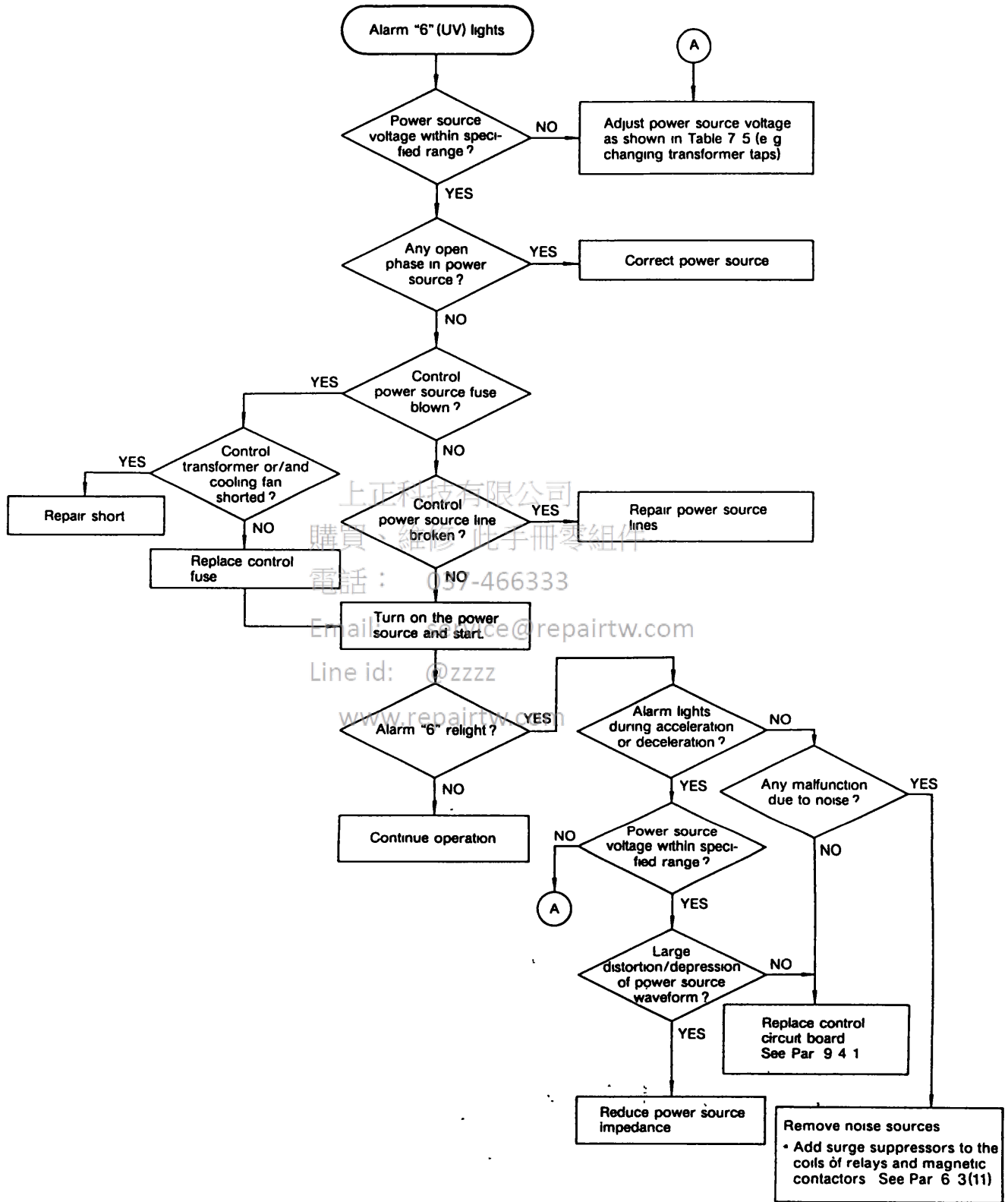

Fig. 9.12 Alarm "6" (UV)

(7) Alarm "7" (OL) lights

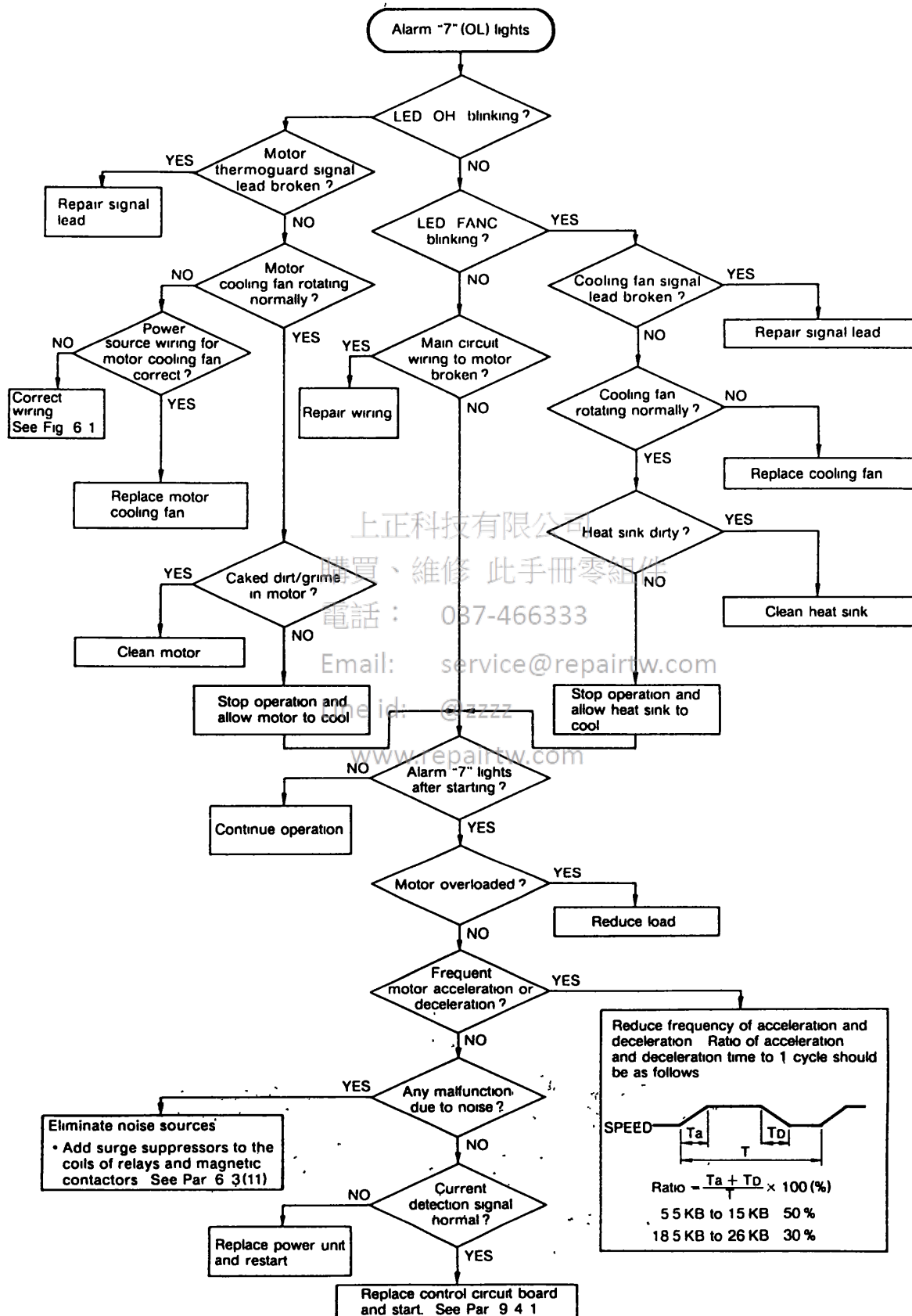

Fig. 9.13 Alarm "7" (OL)

(8) Motor will not rotate

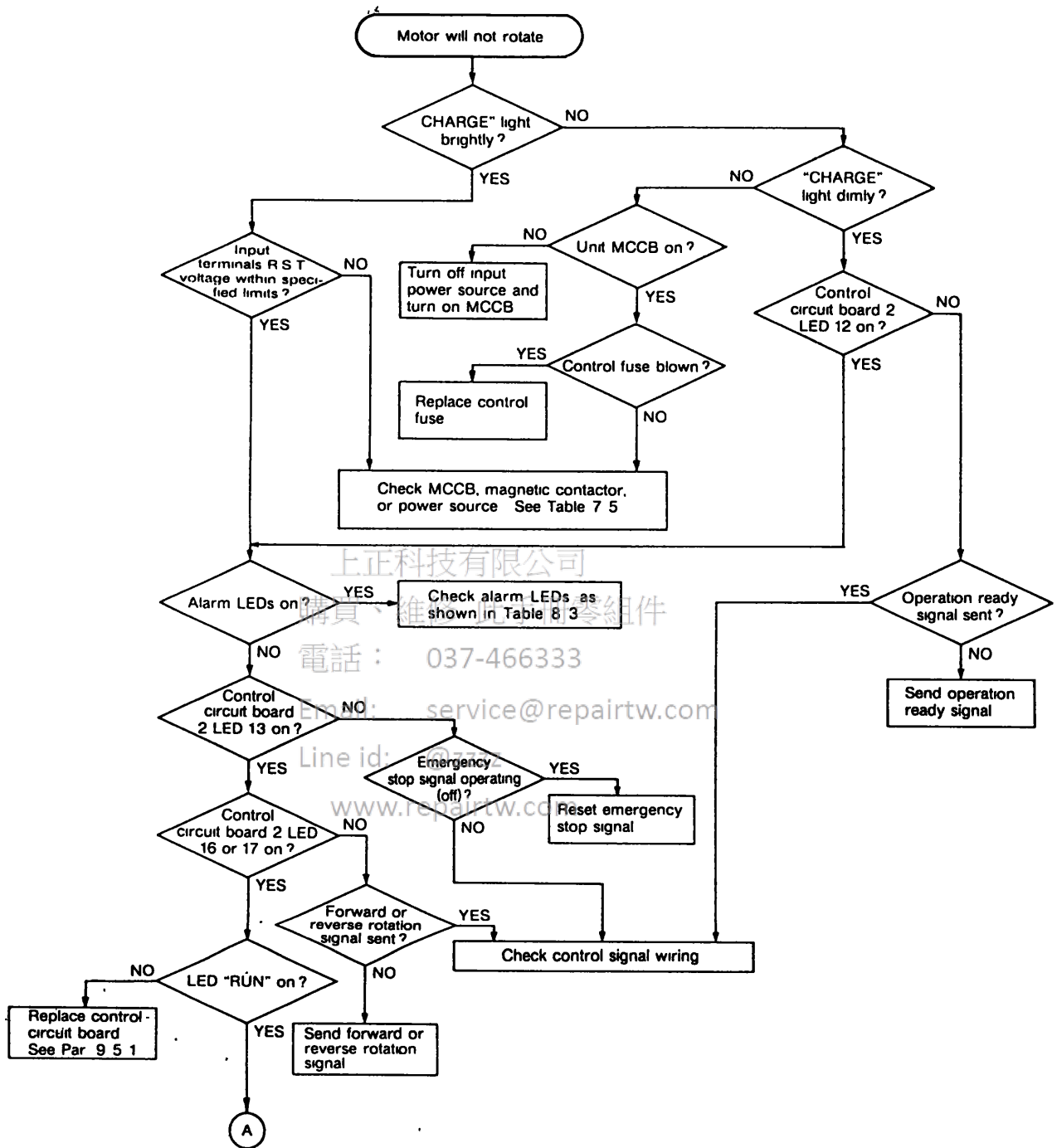

Fig. 9.14 Motor Rotation

(8) Motor will not rotate (Cont'd)

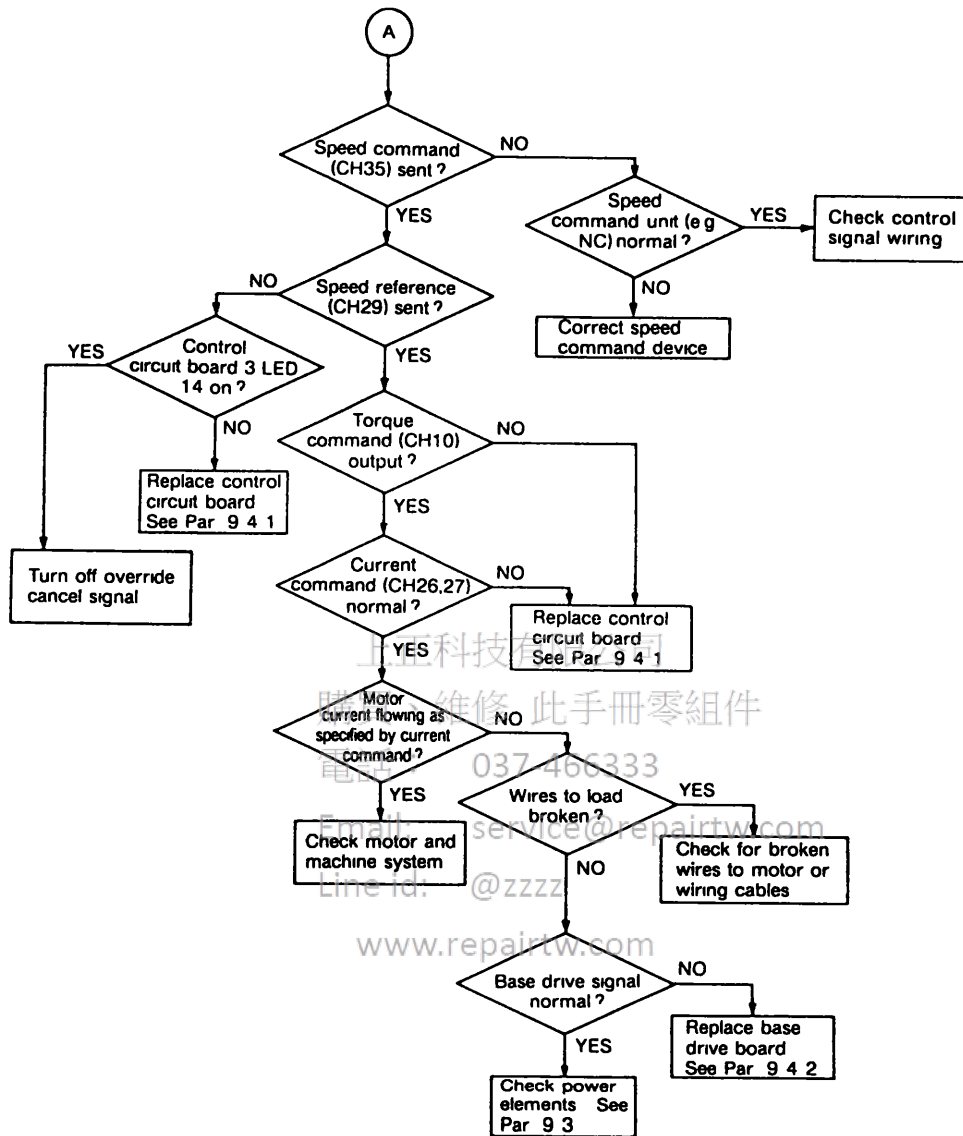

Fig. 9.14 Motor Rotation (Cont'd)

(9) Excessive vibration or noise while motor running

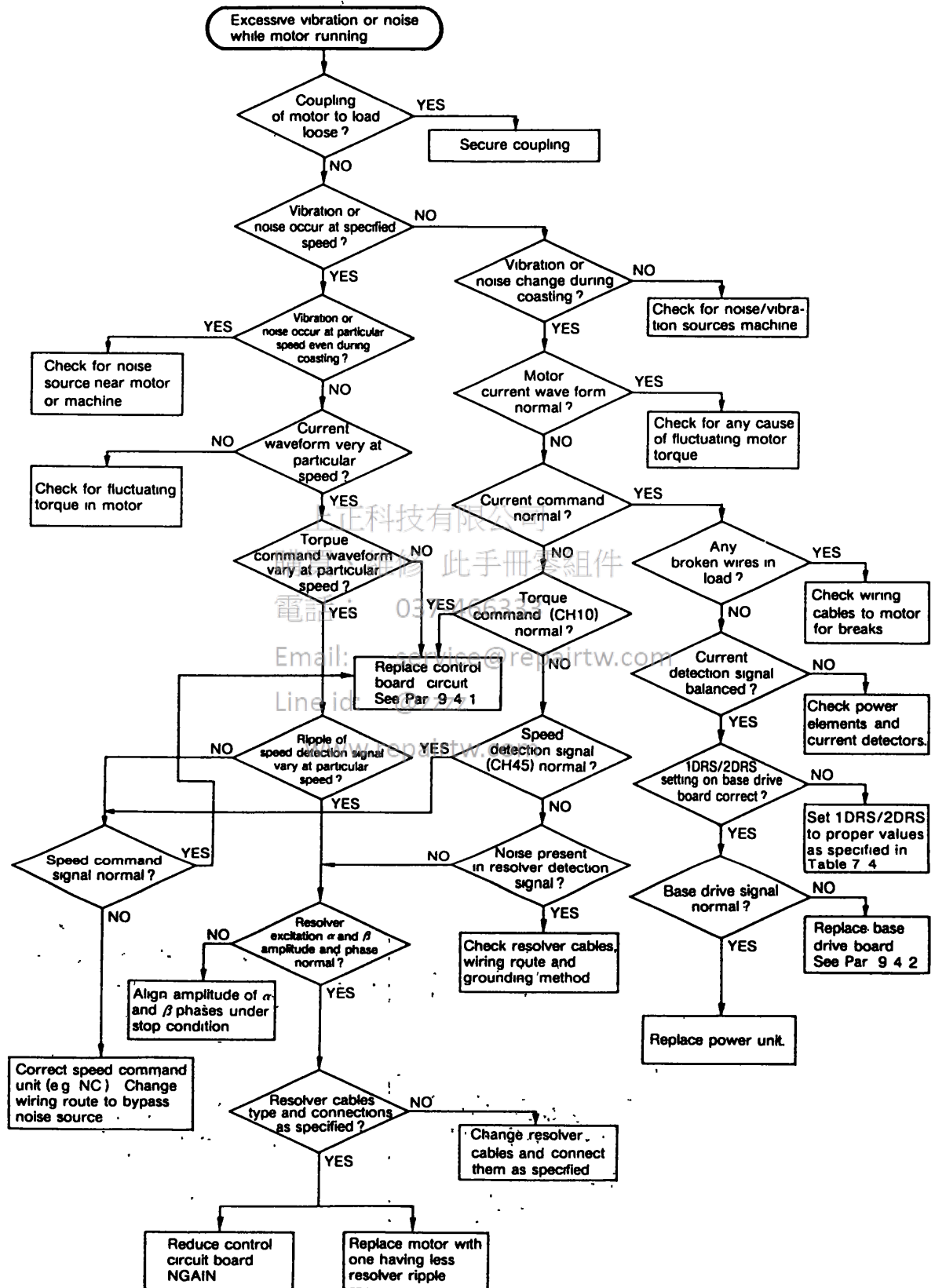

Fig. 9.15 Excessive Vibration or Noise

(10) Acceleration or deceleration time is too long.

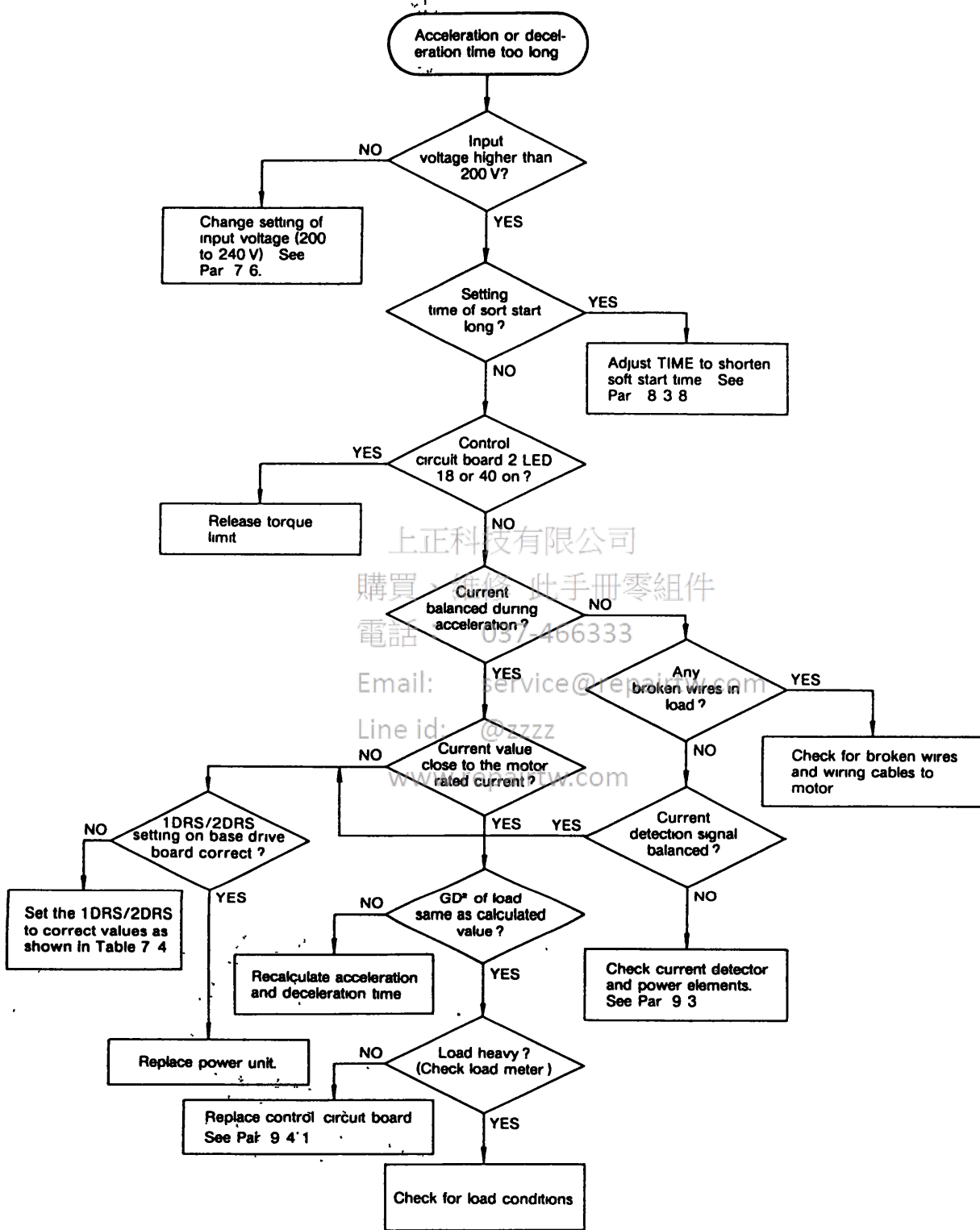

Fig. 9.16 Too long Acceleration or Deceleration Time

10. SPARE PARTS

As insurance against costly downtime, it is strongly recommended that spare parts to be kept on hand in accordance with Table 10.1. When ordering spare parts, please specify to Yaskawa Electric office or representative with: Parts Name, Parts Code No. and Quantity.

Table 10.1 Spare Parts

Parts Name	Type	Code	Q'ty	VS-626MTI Type CIMR-MTI-[]					
				5.5KB	7.5KB	11KB	15KB	18.5KB	22KB
Transistor Module	MG100G1AL3	STR000163	6	6	—	—	—	—	—
	EVK71-050	STR000142	1	1	6	11	11	3	—
	EVL31-055	STR000143	—	—	1	—	—	9	12
Thyristor Module*	MSG100L41A	SCR000235	3	3	3	3	—	—	—
	TM90DZ-H	SCR000198	—	—	—	—	3	3	—
	TM130DZ-H	SCR000238	—	—	—	—	—	—	3
Diode Module	RM60C2Z-H	SID000304	2	2	2	4	4	4	4
DC Circuit Fuse (DCFU)	25SHA75	FU000736	1	1	—	—	—	—	—
	25SH100	FU000697	—	—	1	—	—	—	—
	25SH125	FU000698	—	—	—	1	—	—	—
	25SH150	FU000699	—	—	—	—	1	—	—
	25SH200	FU0007000	—	—	—	—	—	1	1
Control Fuse	GTX-5	FU-000592	2	2	2	2	2	2	2
Cooling Fan	5915PC-22T	FAN000123	1	—	1	1	1	1	1
Control Circuit Board	JPAC-C220	FTC00750X	1	1	1	1	1	1	1
Base Drive Board	JPAC-C221	ETC00751X	1	1	1	1	1	1	1
Snubber Card	—	ETX00241X	1	1	1	1	1	1	1
Surge Absorber	TNR15G471K	XX000139	3	3	3	3	3	3	3

*For types CIMR-MTI-5.5KB to -15KB, thyristor module type TM55DZ-H is also available

Note Code No. suffix for printed circuit board is indicated in X

上正科技有限公司

購買、維修 此手冊零組件

電話： 037-466333

Email: service@repairtw.com

Line id: @zzzz

www.repairtw.com

Varispeed: Patented and registered in U.S.A.



A Better Tomorrow for Industry through Automation

YASKAWA Electric Mfg. Co., Ltd.

TOKYO OFFICE Ohtemachi Bldg., Chiyoda-ku, Tokyo, 100 Japan
Phone (03) 284-9111, -9145 -9146 Telex YASKAWA J33530 Fax (03) 284-9034

TAIPEI OFFICE Union Commercial Bldg., 137, Nanking East Road, Sec. 2, Taipei, Taiwan
Phone (2) 531-7732, 551-7085 Fax (2) 537-3837

YASKAWA ELECTRIC AMERICA, INC.: SUBSIDIARY

Chicago Office/ YASNAC America,

3160 MacArthur Blvd., Northbrook, Illinois 60062, U.S.A.
Phone (312) 291-2348 Telex (230) 270197 YSKW YSNC NBRK Fax (312) 564-3276

Los Angeles Office

14811 Myford Road, Tustin, California 92680, U.S.A.
Phone (714) 731-6841 Telex (230) 678396 YASKAWAUS TSTN Fax (714) 730-8294

New Jersey Office 769 Northfield Ave., Suite 140, West Orange, NJ 07052, U.S.A.
Phone (201) 325-7397 Fax (201) 325-7398

YASKAWA ELECTRIC EUROPE GmbH: SUBSIDIARY

Monschauerstrasse 1, 4000 Düsseldorf 11, West Germany
Phone (0211) 501127 Telex (41) 8588673 YASD D Fax (0211) 507737

Due to ongoing product modification/improvement, data subject to change without notice.